

# Motor Modeling Based on Physical Effect Models

Dirk Dammers<sup>1</sup>, Patrice Binet<sup>1,3</sup>, Georg Pelz<sup>2</sup> and Lars M. Voßkämper<sup>1</sup>

<sup>1</sup> Dolphin Integration GmbH, Bismarckstr. 142a, D-47057 Duisburg, Germany

<sup>2</sup> Infineon Technologies AG, St.-Martin Str. 76, D-81541 Munich, Germany

<sup>3</sup> Ecole Centrale de Lyon, 36 avenue Guy de Collongue, 69131 Ecully Cedex, France

## Abstract

Modeling of complex electromechanical systems can be simplified by dividing the mechanical part of the system into basic physical effects. These basic physical effects have been used for microsystem modeling [1] and – as shown in this paper – can also be used in modeling electro-mechanics of macro scale. The reuse of these models from a library of basic effects in other systems saves time and money. This is illustrated through the example of a hard disk drive's electro-mechanics, i.e. spindle motor and voice coil motor.

**Keywords:** Permanent Magnet Brushless DC Motor (PMBDCM), Voice Coil Motor (VCM), macro system modeling, electromechanical effects, VHDL-AMS

## Introduction

Much work has been devoted to object-oriented modeling in the past [5]. Here each device is modeled separately. The physical effect approach goes one step further. Its basic idea is to model effects that occur in or between electromechanical devices. These basic effect models are combined into device models, e.g. plate, suspension or drive models. For example, one could dissect the mechanics of an electrical motor into torque generation, inertia, friction, load torque, back-EMF and so on. The advantage of this kind of modeling is that the designer can decide which effects are necessary and which effects can be neglected. So he is able to influence the simulation accuracy and the simulation speed.

Another advantage of using effect models is that they are highly reusable. For example: the inertia effect and the capacity effect in the following macro mechanical examples of brushless dc motors are already used in a micro mechanical model of a gyroscope [1].

## Electromechanical Components of a Hard Disk

The electromechanical components of a hard disk, i.e. motors, disk and head assembly, are shown in Fig. 1. The spindle motor is used to turn the disk in a constant rotation. The voice coil motor moves the read/write head onto the requested track to read or write data.

We can identify the following effects in the hard disk device:

### Electrical effects

**resistance:**

$$(1) \quad V = R \cdot I$$

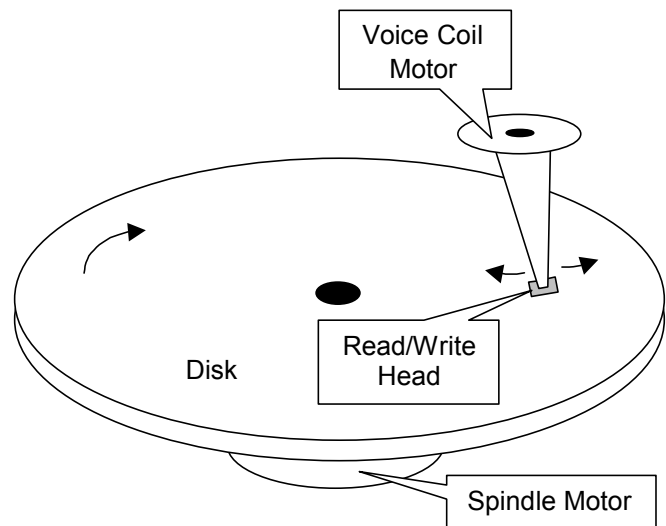

Fig. 1: Electromechanical components of a hard disk

I : current in resistor  
R : value of resistor  
V : voltage across resistor

**capacitance:**

$$(2) \quad I = C \cdot \frac{dV}{dt}$$

C : value of capacitance  
I : current in resistor  
V : voltage across capacitance

**inductance:**

$$(3) \quad V = L \cdot \frac{dI}{dt}$$

I : current in inductance  
L : value of inductance  
V : voltage across inductance

**mutual inductance between two windings:**

$$(4) \quad V_1 = M \cdot \frac{dI_2}{dt}$$

$$(5) \quad V_2 = M \cdot \frac{dI_1}{dt}$$

$$(6) \quad M = C_m \cdot \sqrt{L_1 \cdot L_2}$$

$C_m$  : coupling factor  
 $I_1$  : current in inductance 1  
 $I_2$  : current in inductance 2  
 $L_1$  : value of inductance 1  
 $L_2$  : value of inductance 2  
M : mutual inductance

- $V_1$  : voltage induced in inductance 1  
 $V_2$  : voltage induced in inductance 2

### Electromechanical effects

#### back-EMF:

$$(7) \quad V_{bn} = C_b \cdot \frac{d\Theta}{dt} \sin\left(A \cdot \Theta - (N-1) \cdot \frac{2\pi}{P}\right)$$

- A : number of pole pairs on the rotor  
 $C_b$  : back-EMF voltage constant  
N : phase number  
P : number of motor phases  
 $\theta$  : motor shaft angle  
 $V_{bn}$  : back-EMF voltage for the phase N winding

#### drive torque:

$$(8) \quad T_{dn} = C_t \cdot i_{pn} \cdot \sin\left(A \cdot \Theta - (N-1) \cdot \frac{2\pi}{P}\right)$$

- A : number of pole pairs on the rotor  
 $C_t$  : torque constant  
 $i_{pn}$  : current in the phase N winding  
N : phase number  
P : number of motor phases  
S : shaft speed  
 $T_{dn}$  : drive torque from the phase N winding  
 $\theta$  : motor shaft angle

### Mechanical effects

#### inertia torque:

$$(9) \quad T_{inr} = J \cdot \frac{d^2\Theta}{dt^2}$$

- J : moment of inertia of rotor  
 $T_{inr}$  : inertia torque  
 $\theta$  : motor shaft angle

#### damping losses:

$$(10) \quad T_{damp} = C_{damp} \cdot \frac{d\Theta}{dt}$$

- $C_{damp}$  : damping losses constant  
 $T_{damp}$  : damping torque losses  
 $\theta$  : motor shaft angle

#### eddy current losses:

$$(11) \quad T_{eddy} = C_{eddy} \cdot \frac{d\Theta}{dt}$$

- $C_{eddy}$  : eddy current losses constant  
 $T_{eddy}$  : eddy current torque losses  
 $\theta$  : motor shaft angle

#### friction losses:

$$(12) \quad T_{frc} = F_c \cdot \frac{d\Theta}{dt}$$

- $F_c$  : friction losses constant  
 $T_{frc}$  : friction losses torque  
 $\theta$  : motor shaft angle

#### detention torque:

$$(13) \quad T_{det} = D \cdot \sin(N_d \cdot A \cdot \Theta)$$

- A : number of pole pairs on the rotor  
D : magnetic detention torque constant  
 $N_d$  : integer determined by the number of stator slots and the motor structure  
 $T_{det}$  : magnetic detention torque  
 $\theta$  : motor shaft angle

### Spindle Motor

The Permanent Magnet Brushless DC Motor (PMBDCM) is a good example of a complex macro electromechanical device. PMBDCM are used in computer disk drives and other applications where precise control of motor operation is required. Other advantages of PMBDCM are the high maximum speed, absence of maintenance requirements and the low noise emission.

The permanent magnets of the PMBDCM are mounted on the rotor whereby the electromagnets are arranged around the stator, see Fig. 2. The permanent magnets create the rotor flux. The current flowing through the stator windings creates the electromagnet poles. The torque is generated by these electromagnet poles, which are attracting the rotor.

A rotating field on the stator is used to turn the rotor continuously. This is to be done by applying a power supply to the stator windings in a suited sequence. That means that the power supply depends to the rotor angle.

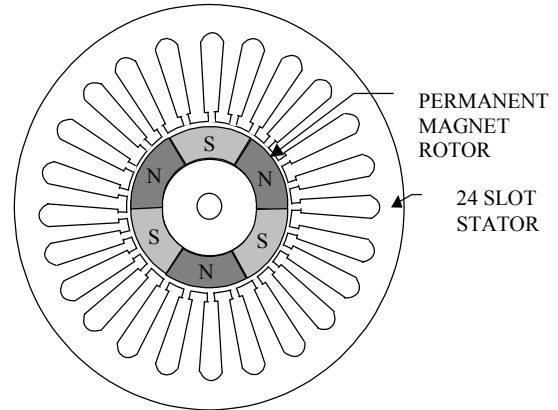

Fig. 2: Structure of a brushless dc motor

Fig. 3 shows the schematic of a 3-phase spindle motor. For modeling the electrical part, i.e. the windings, we used the resistor, the capacitance, the inductance and the mutual inductance. The mechanical part consists of the inertia of the rotor, the detention torque due to the magnetic field, the friction due to the bearings, the damping due to the airflow and the eddy current losses of current flows induced in the stator. The electro mechanical part contains the drive torque caused by the magnetic field of the currents through the windings and the back-EMF effect, which is caused by the rotating rotor field in the stator windings.

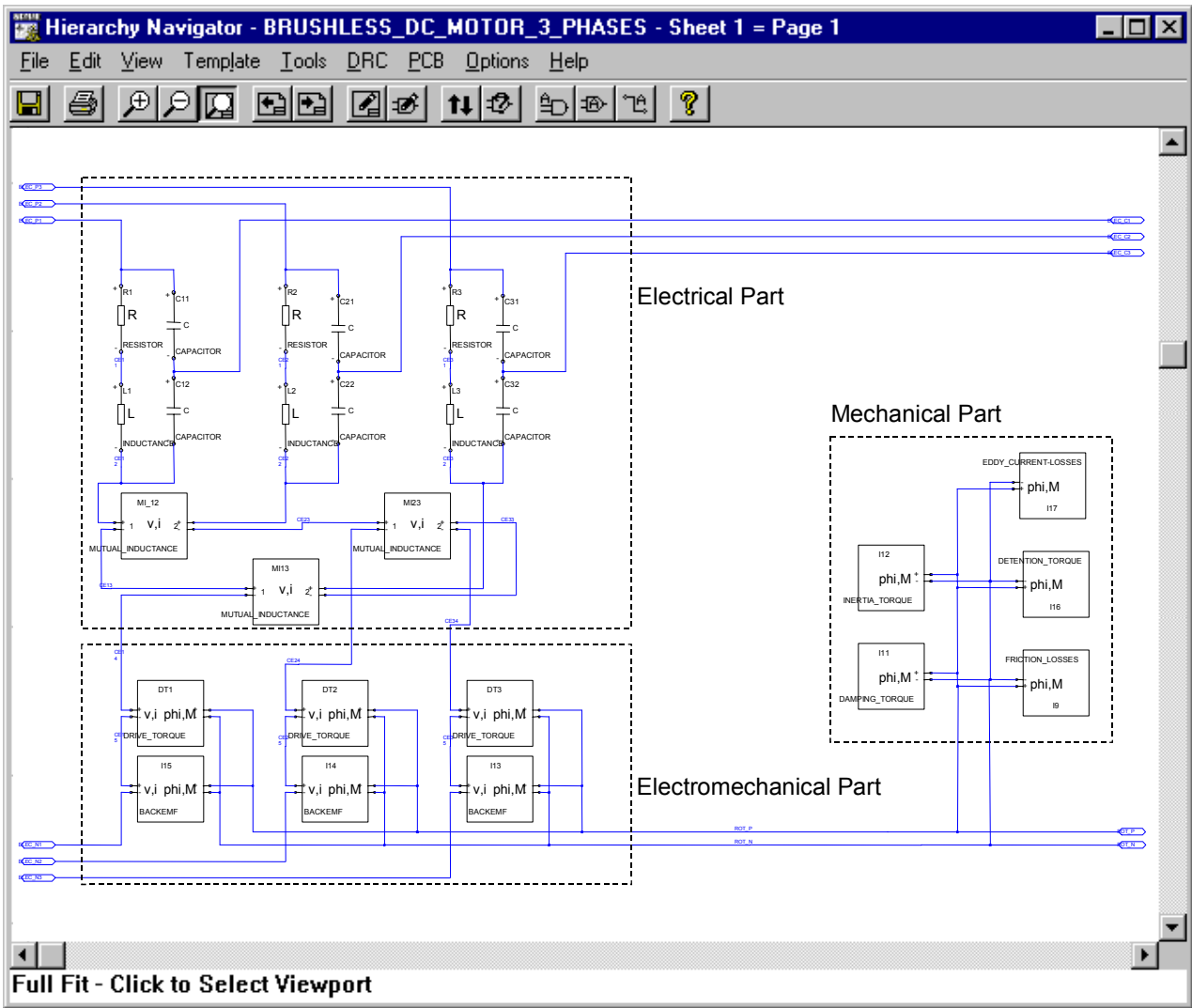

Fig. 3: Schematic of the PMBDCM

### Voice Coil Motor

The Voice Coil Motor (VCM) is designed to position the read/write head very fast and precise onto the requested track. Fast positioning requires small masses and the required high resolution in positioning efforts a movement of the motor in a continuously way: the VCM's coil moves within *one* pole pair in contrast to the rotor movement of the spindle motor.

The stator of the VCM, in contrast to the PMBDCM, is built of a permanent magnet. The rotor consists of a coil, a pivot and an arm where the read/write head is mounted, see Fig. 4. Due to this construction the motion range is typically limited to 20-40 degrees.

The effects used in the model of the VCM are: resistance, inductance, back-EMF, drive torque, inertia torque, damping losses and friction losses. These effect models are already used to model the spindle motor with, of cause, different parameters. This should demonstrate the high reusability of the basic effect model library. Fig. 5 shows the schematic of the VCM.

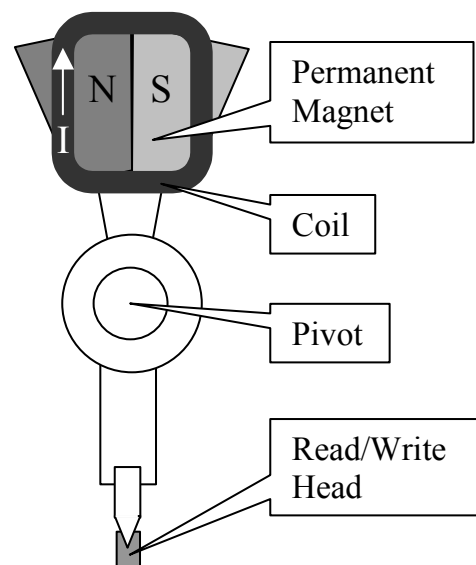

Fig. 4: Structure of a VCM

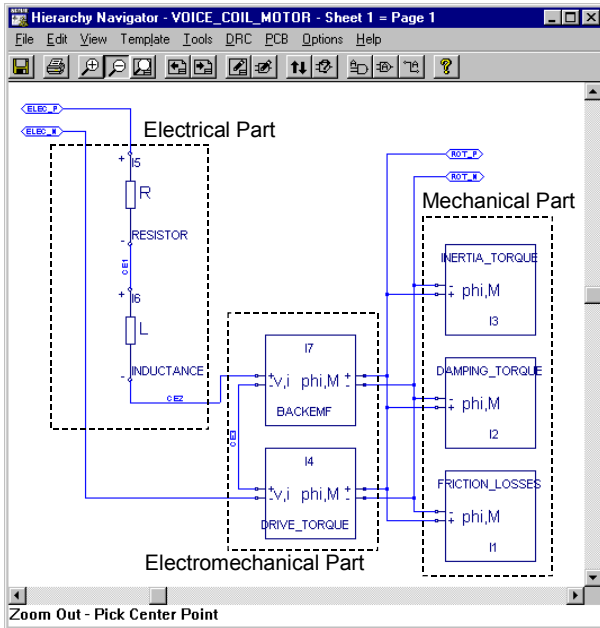

Fig. 5: Schematic of the VCM

### Implementation

In VHDL-AMS we are not restricted to pre-given variable types. Which is on one hand an advantage because we can implement variable types of non-electrical domains that we want to integrate in the simulation. But on the other hand it means a disadvantage, since the exchange of models of different suppliers becomes aggravated. Because of the lack of an official standard for non-electrical variable types each supplier chooses his own solution.

Nevertheless, VHDL-AMS provides a comfortable definition possibility of user defined variable types. We have chosen the in Table 1 shown “through” and “across” types for the ports of the different models. This restrict port definition for each domain assure that the effect models are compatible with each other in connection case and provide an easy extension of the model library.

type of variable	electrical network	rotational movement	translational movement
"through"-variable	current $i$	torque $T$	force $F$
"across"-variable	voltage $v$	angle $\varphi$	displacement $x$

Table 1: Variable types of the implemented ports for each domain

A demonstration of the effect implementation is given in Listing 1, which describes the damping losses of equation (10). Please notice the straightforward implementation possibility of mathematical equations provided by VHDL-AMS.

```

USE work.math_real.all;
USE work.rotational_system.all;

ENTITY damping_torque IS
  GENERIC (Cdamp : REAL := 3.6e-6);
  PORT (TERMINAL rot_p,
        rot_n: ROTATIONAL);
END ENTITY damping_torque;

ARCHITECTURE simple OF damping_torque
IS
  QUANTITY theta ACROSS Tdamp THROUGH
  rot_p TO rot_n;

BEGIN
  Tdamp == Cdamp * theta'dot;
END ARCHITECTURE simple;

```

Listing 1: VHDL-AMS implementation of the damping losses

### Simulation of the spindle motor

After identifying the basic effects, implementation of these effects in VHDL-AMS and combining these effects to the motor device, we have modeled a basic control circuit to complete the macro electromechanical system. For simulation we used the mixed signal and mixed language simulator SMASH<sup>1</sup>.

The simulation results of the PMBDCM are shown in Fig. 6. During the first 800ms the power supply is attached to the motor. After this the power supply is disconnected for 100ms. Finally the motor clamps are connected to Ground.

The rows in Fig. 6 show the produced drive torque per phase, the rotor speed, the resulting drive torque, the power supply per phase and the back-EMF per phase. The peaks on the drive torque curve and also in the shaft speed curve results from the implementation of a very simple phase power supply circuit.

### Simulation of the voice coil motor

Fig. 7 shows the simulation results of the VCM. The task of the motor is to position the head over a requested track. We have converted the angle of the actuator into a track number. The simulation starts at track 0 at  $t=0s$ , after 1ms track 2000 is requested. Track 2000 is reached at about  $t=6.5ms$ . At  $t=7ms$  track 500 is requested, what is attained at about  $t=11.5ms$ .

Fig. 7 shows the produced drive torque, the angular velocity of the actuator arm, the back-EMF, the voltage attached to the motor clamps, the current through the VCM, the requested and the actual track.

The used control circuit is very simple and supposed only for demonstrating purposes. Replacing of this simple control unit with an existing one supports the designing of such highly interacting electromechanical systems.

<sup>1</sup> Dolphin Integration S.A., Grenoble, France.

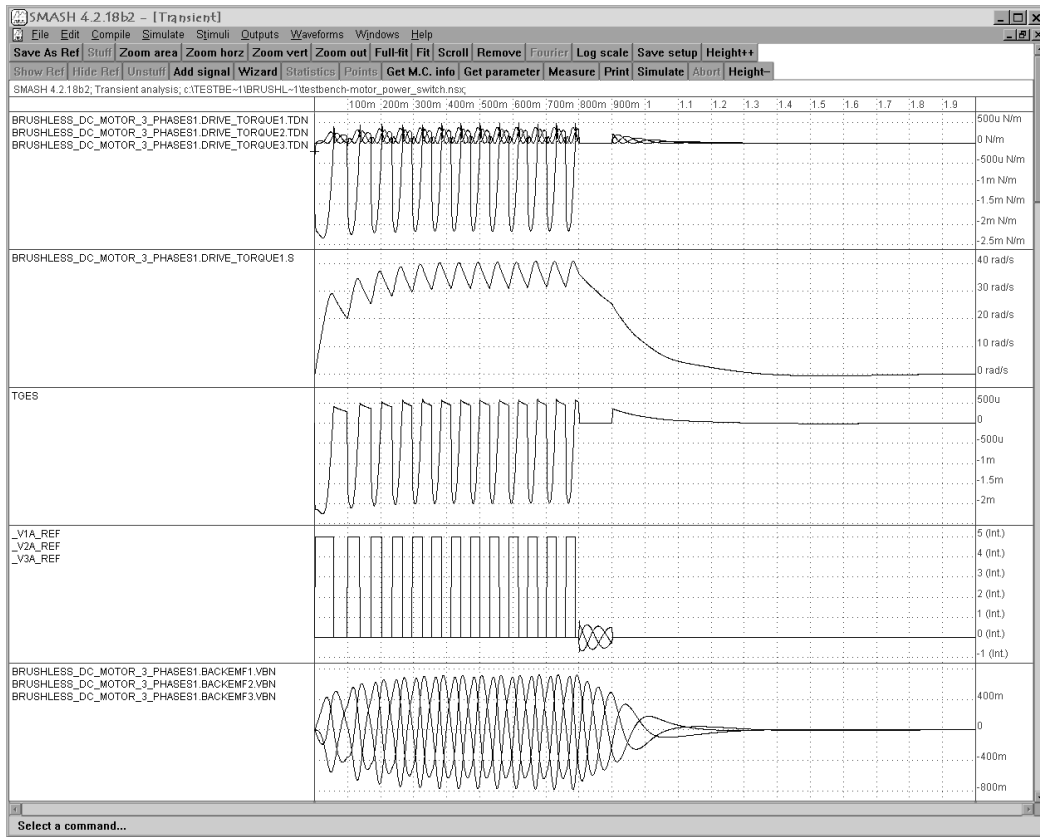

Fig. 6: Simulation of the PMBDCM: drive torque per phase, rotor speed, resulting drive torque, power supply per phase, back-EMF per phase

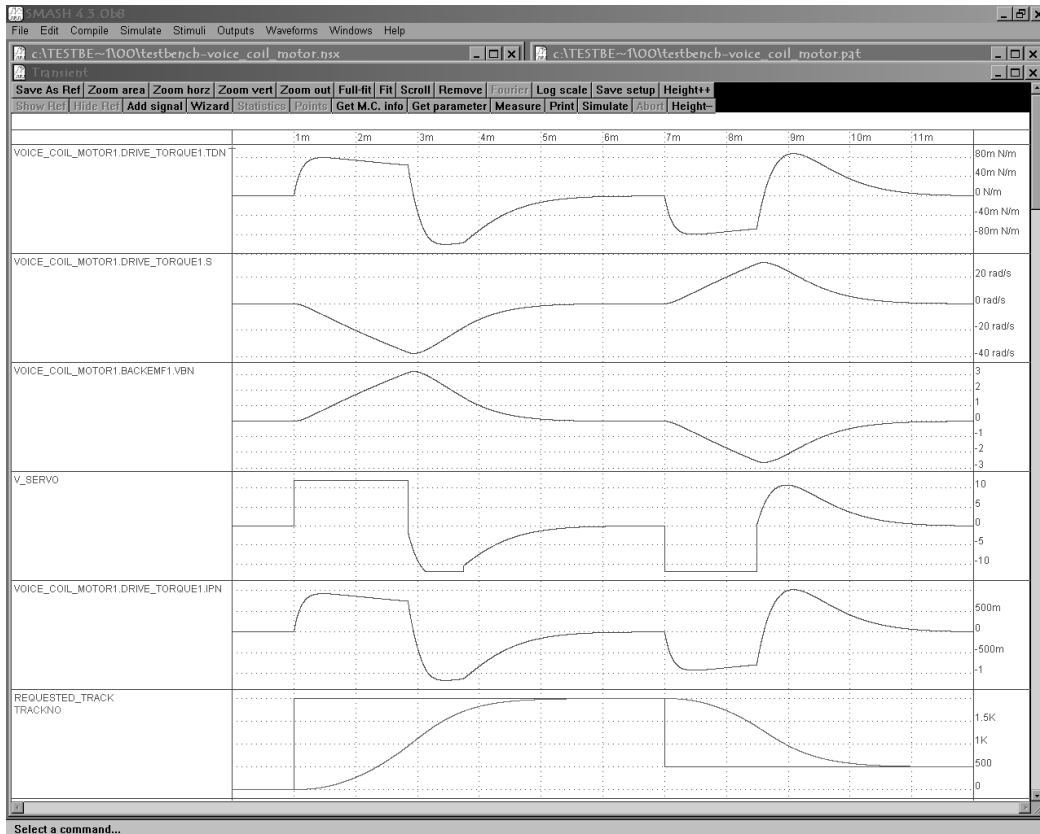

Fig. 7: Simulation of the VCM: drive torque, rotor speed, back-EMF, applied voltage, motor current, requested and actual track

## Conclusion and Outlook

The implementation of the needed mathematical equations in the hardware description language VHDL-AMS was simple due to its flexible quantity handling.

The introduced models extend the model library of electrical circuit simulation tools supporting VHDL-AMS with electromechanical effects. So the specific requirements of electromechanical systems regarding mixed domain simulation needs are supported and a system modeling and simulation becomes easier, faster and safer.

The shown examples demonstrate that the use of a library of basic effect models for modeling the electromechanical part of a system saves time and money due to its good reusability. Moreover the development of new system models is simplified.

Adding a model of an existing motor drive control and an electronic control of the voice coil motor, it becomes possible to simulate a complete hard disk system. So developers can optimize such systems and reduce the amount of time and money in building expensive prototypes.

## Literature

- [1] L. M. Voßkämper, R. Schmid and G. Pelz, "Combining Models of Physical Effects for Describing Complex Electromechanical Devices", IEEE/VIUF Workshop on Behavioral Modeling and Simulation (BMAS), Orlando, Florida, 2000.
- [2] J. Bielefeld, G. Pelz and G. Zimmer, "AHDL-Model of a 2D Mechanical Finite-Element usable for Micro-Electro-Mechanical Systems", IEEE/VIUF Workshop on Behavioral Modeling and Simulation (BMAS), Washington D.C., 1997, 177-182.
- [3] G.K. Fedder, Q. Jing,, "NODAS 1.3 - Nodal Design of Actuators and Sensors", IEEE/VIUF Workshop on Behavioral Modeling and Simulation (BMAS) 1998
- [4] J. R. Hendershot jr. and T. Miller, "Design of Brushless Permanent-Magnet Motors", Magna Physics Publications ISBN 1-881855-03-1
- [5] M. Otter, "Objektorientierte Modellierung Physikalischer Systeme, Teil 1", at - Automatisierungstechnik 47 (1999) 1, R. Oldenbourg Verlag
- [6] P. Buttolo, D.Y. Hwang, P.H. Marbot, B. Hannaford, "Hard Disk Actuators for Mini Teleportation", Proceedings SPIE, Telem manipulator and Telepresence Technologies Symposium, Boston, 1994.