

---

***High Frequency Lumped Element  
Models for Substrate Noise  
Coupling***

**Cheng-gang Xu, Terri Fiez and  
Karti Mayaram**

**School of EECS  
Oregon State University  
Corvallis, OR 97331**

# Outline

---

- Introduction
- Numerical methods
- Frequency dependence of substrate parasitics
- Equivalent circuit models for substrate coupling
- Conclusions

# Substrate Noise Coupling From Digital to Analog

- Circuit isolation is a key problem for SoC's
  - ✓ Increasing integration of analog and digital circuits
  - ✓ Increasing operating frequency

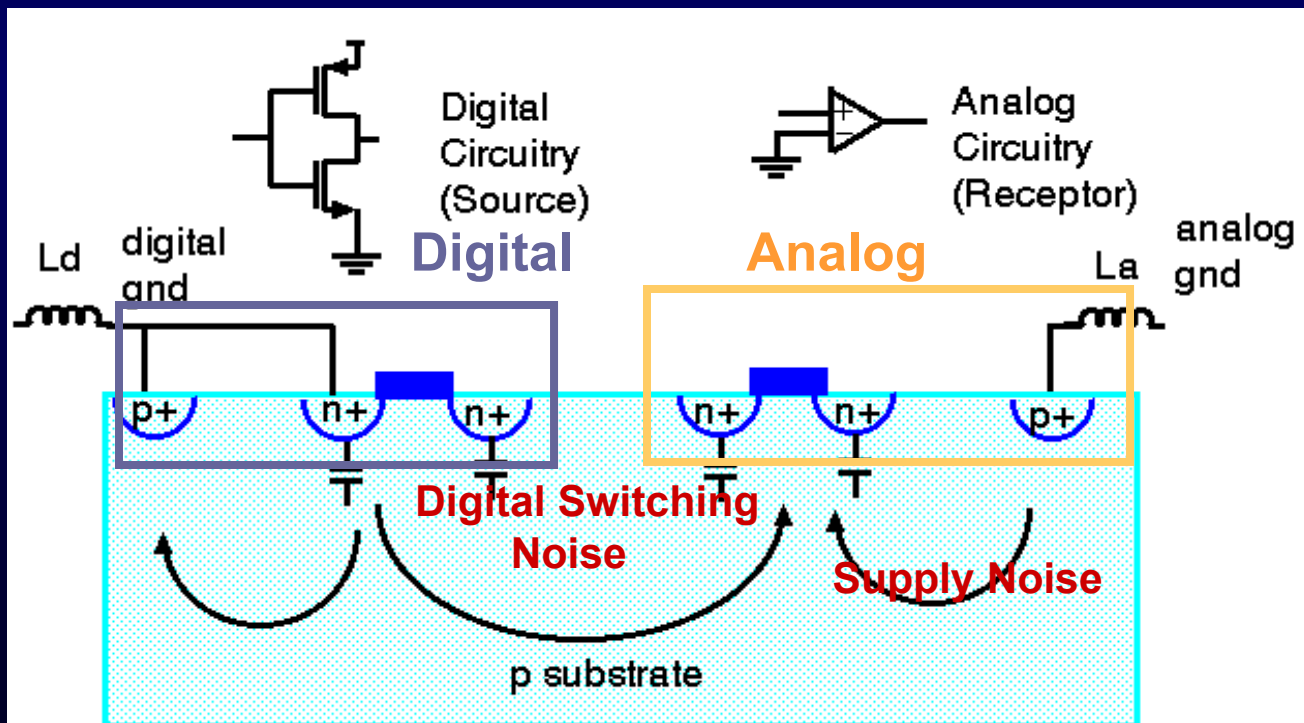

# Two Contacts and a Generic Lumped Model

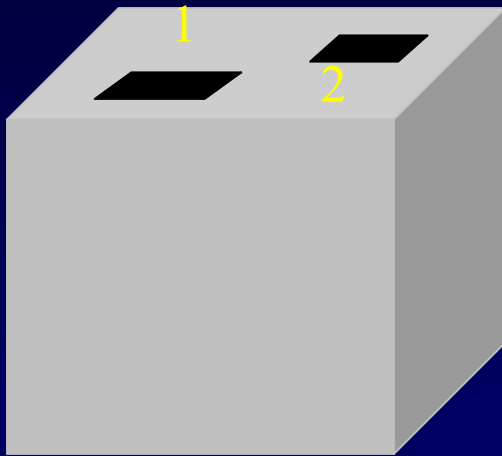

Two contacts in a substrate

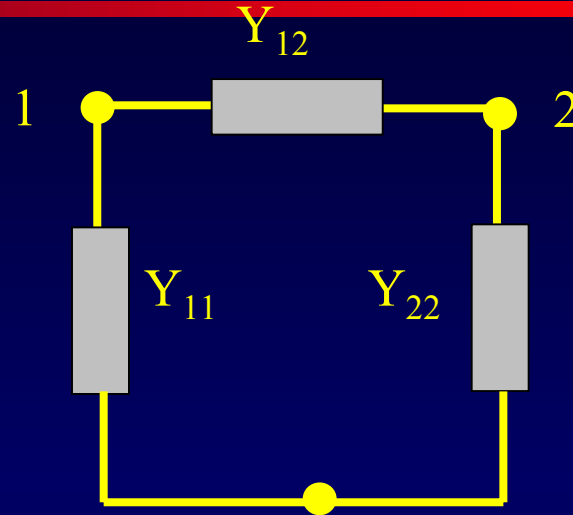

Equivalent circuit model

- For frequencies  $< 1$  GHz admittances are modeled as resistors
- For high frequencies dielectric behavior of substrate must be included
  - ✓ Capacitors included in equivalent circuit model

# Numerical Methods for Admittance Extraction

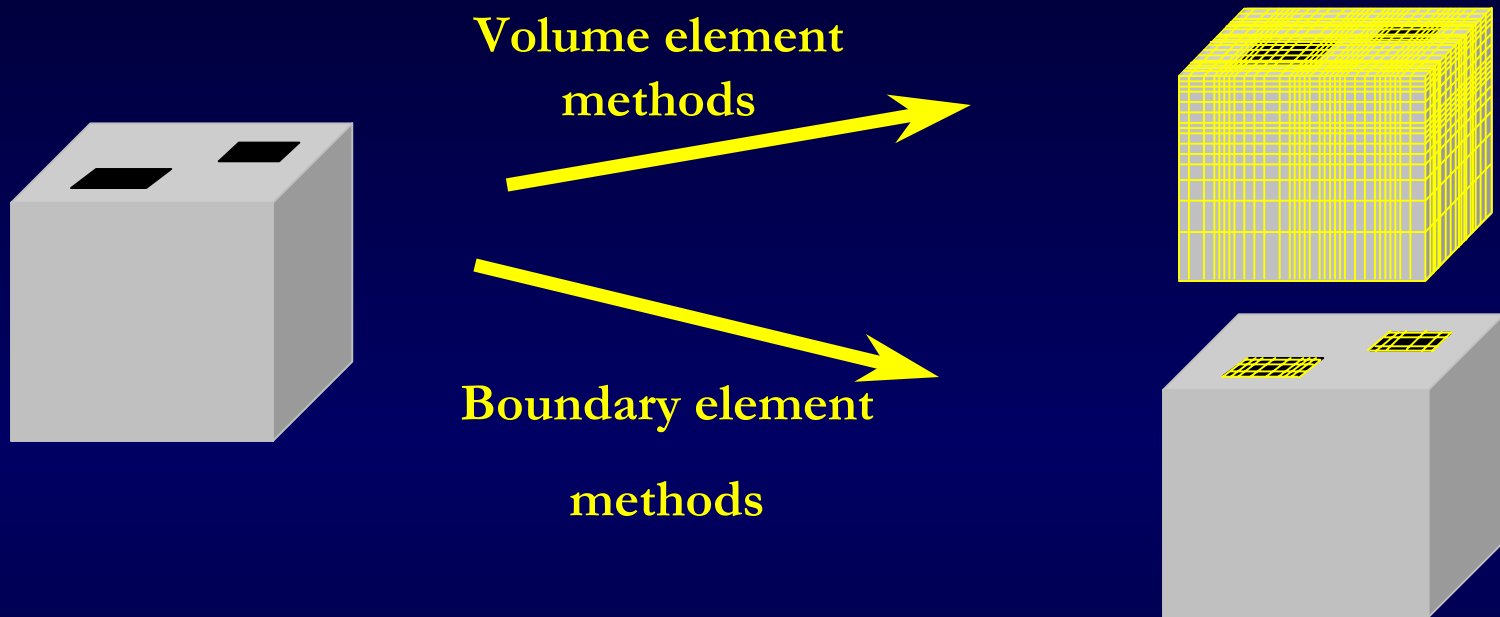

- Volume element methods are versatile but expensive
- Boundary element method is computationally efficient

# ***Substrate Coupling Roadmap***

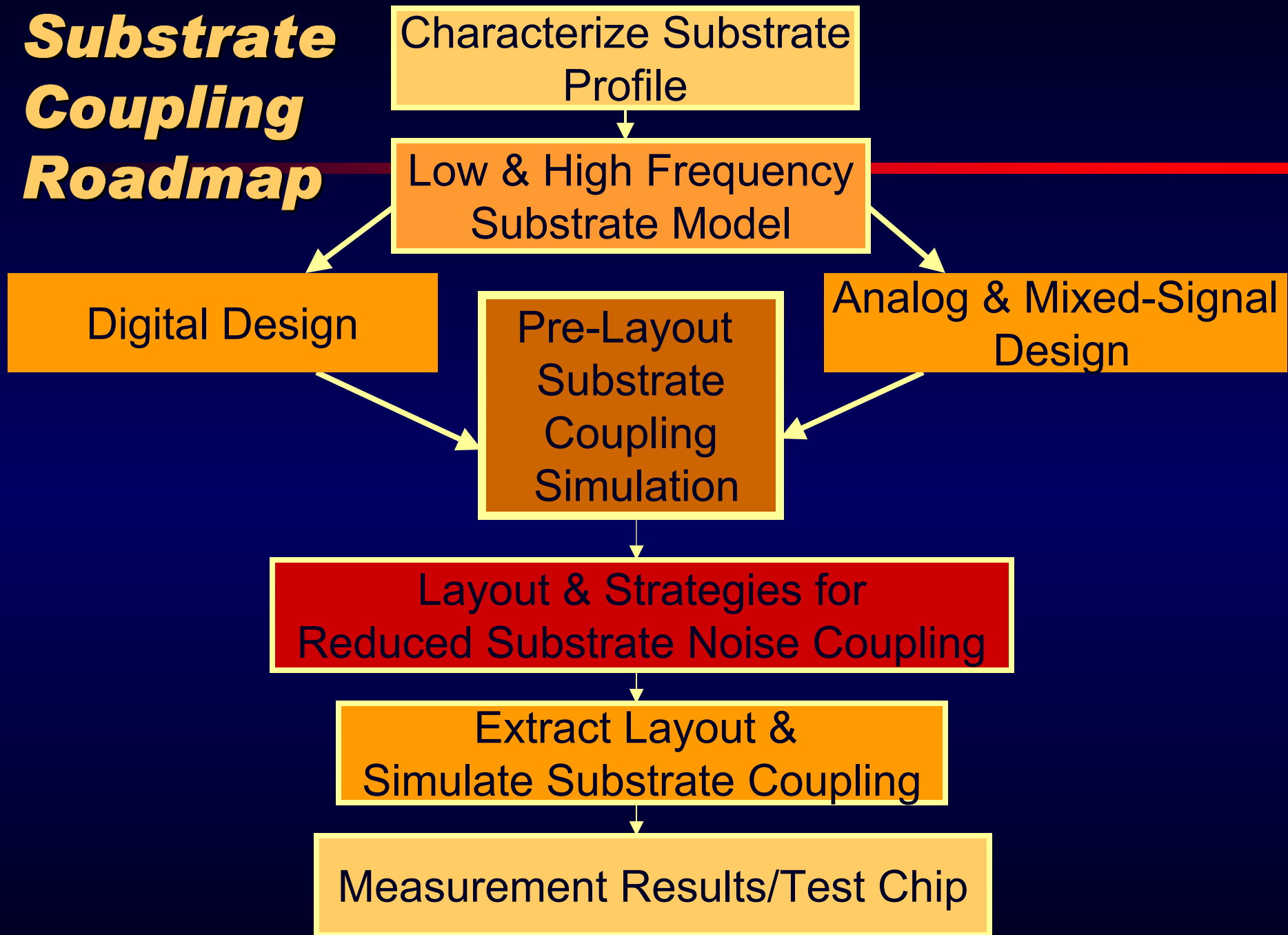

# Previous High Frequency Analysis

- High frequency coupling behavior and models
  - ✓ Capacitive behavior [R. Gharpurey, 1997]
  - ✓ Inductive behavior [H. Li, et. al, 2002]
  - ✓ Equivalent circuit models [H. Lan, 2003]

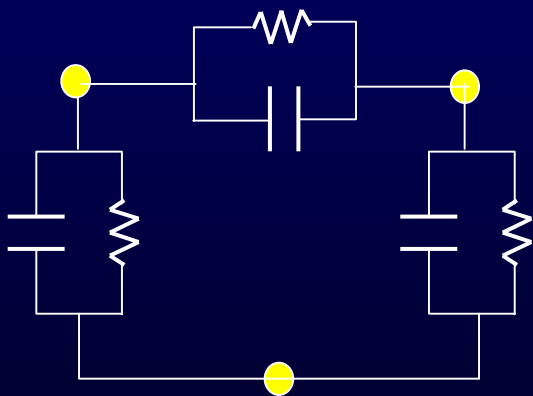

Model I

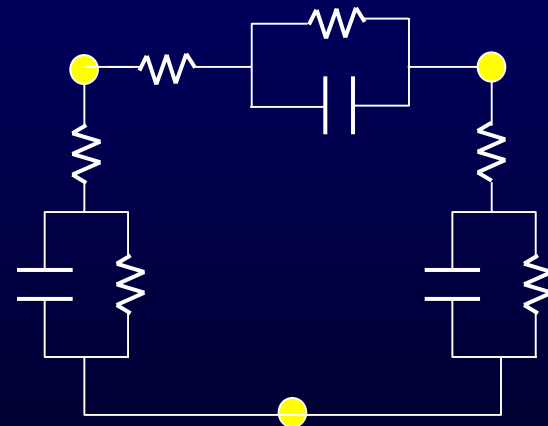

Model II

# High Frequency Numerical Simulator

---

- EPIC - a Green's function based solver for Extraction of Parasitics for IC's
  - ✓ Multilayered approximation of substrate doping profile
  - ✓ Each layer is characterized by a complex conductivity  $\sigma_c = \sigma + j\omega\varepsilon$
  - ✓ Numerically stable implementation

# Lightly And Heavily Doped Substrates

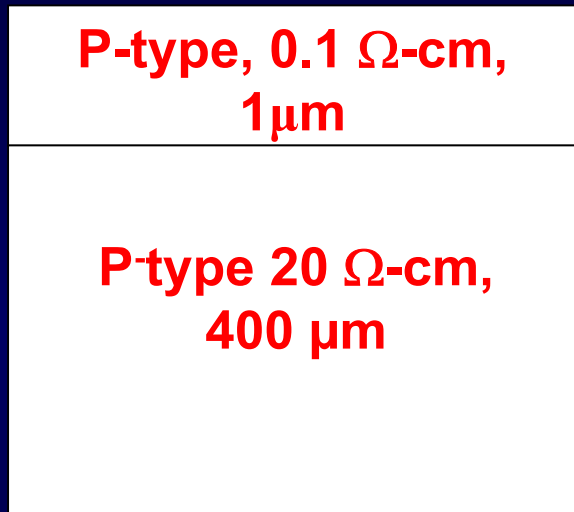

**Lightly doped substrate**

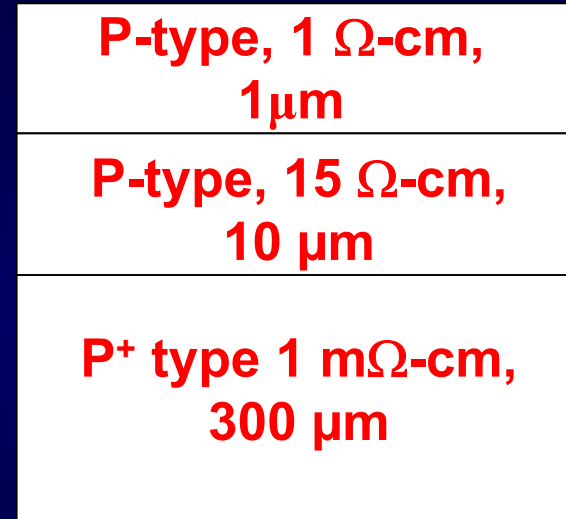

**Heavily doped substrate**

- Layered approximation for the doping profile

# Frequency Dependence of Self Admittance ( $Y=G+jB$ )

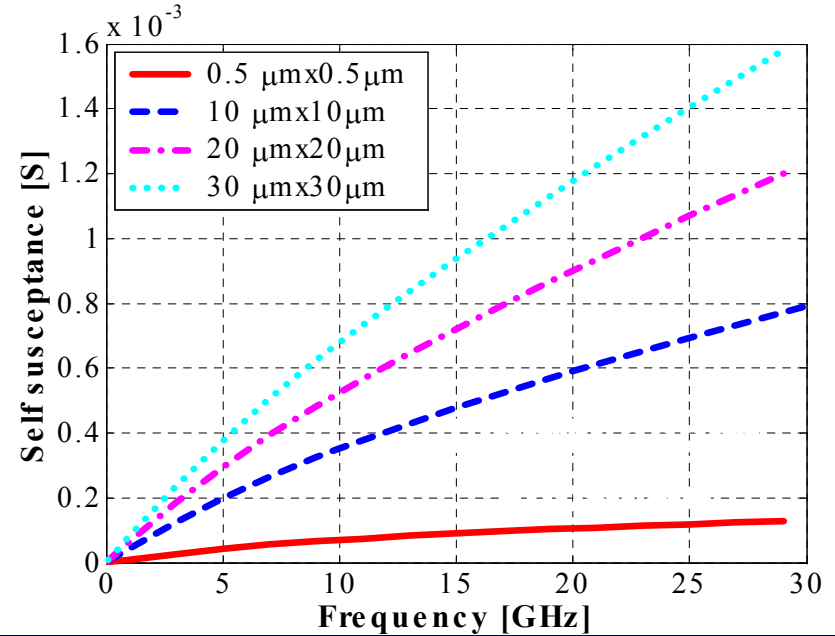
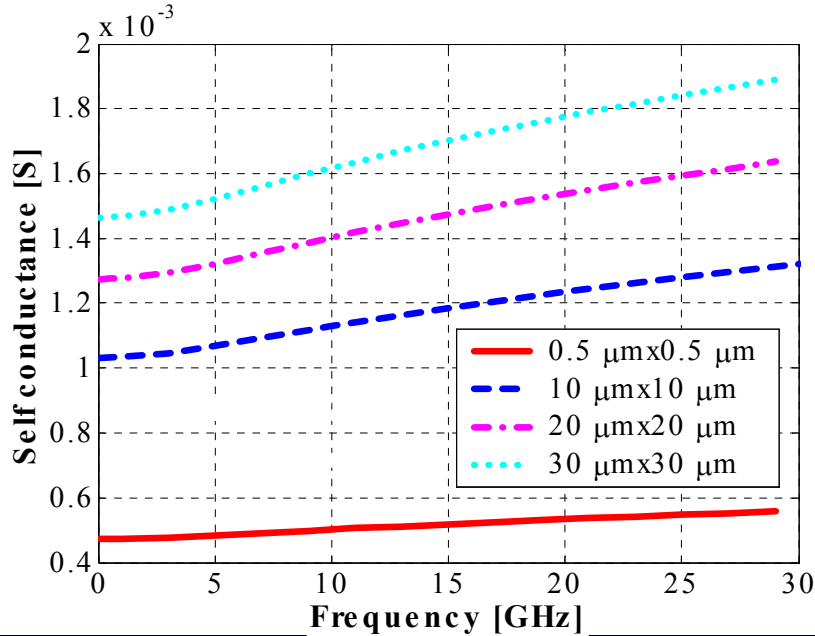

- Self admittance behaves capacitively
- Coupling between larger contacts more frequency sensitive
- Conductance nearly constant for frequencies  $< 5\text{GHz}$
- Susceptance increases linearly for frequencies  $< 5\text{GHz}$

# Self Admittance Models

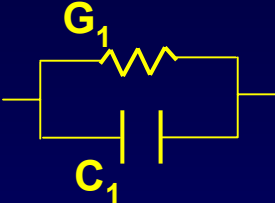
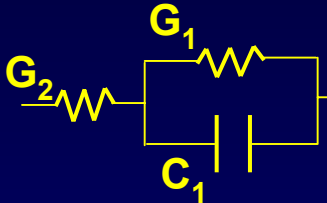
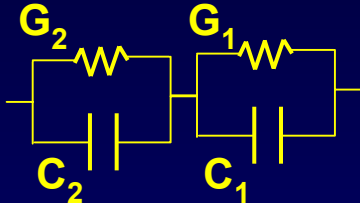
	Model 0	Model I	Model II	Model III
Circuit				
Suitable frequency range	$f < 1 \text{ GHz}$	$1 \text{ G} < f < 5 \text{ G}$	$5 \text{ G} < f < 10 \text{ G}$	$f > 5 \text{ GHz}$
Comments	Simplest low frequency model	Cannot model the frequency dependence of G	Models the frequency dependence of G and B	Similar to Model II but with better agreement with simulations

- Model 0 through Model II are existing models
- Model III proposed new model

# Self Admittance Model II and Model III Comparisons

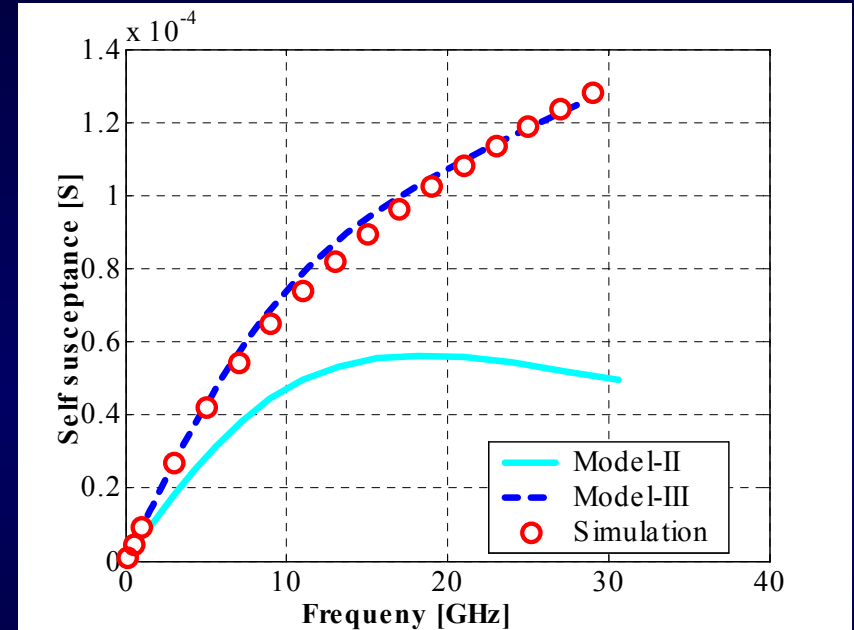
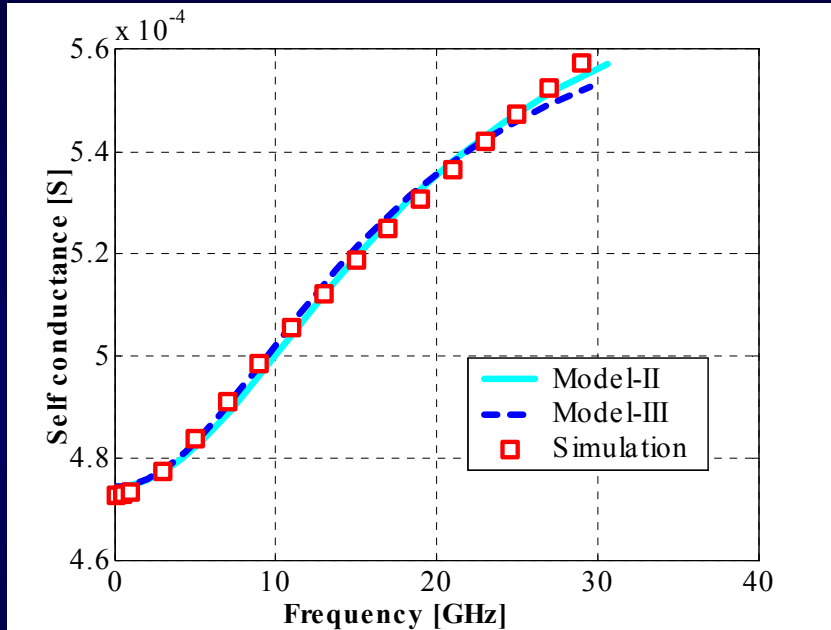

- Conductance and susceptance in Model II do not fit data simultaneously

# Frequency Dependence of Mutual Admittance ( $Y=G+jB$ )

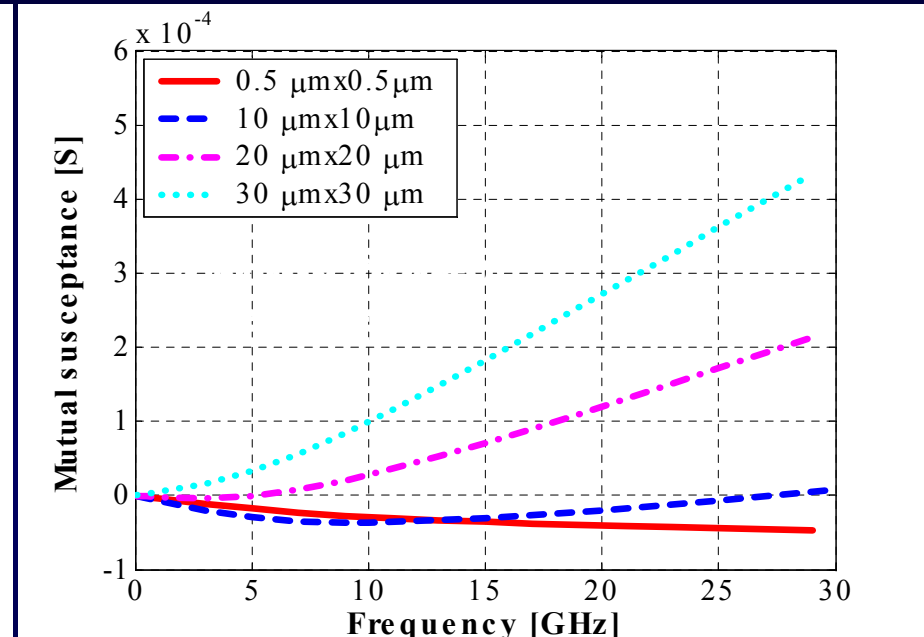
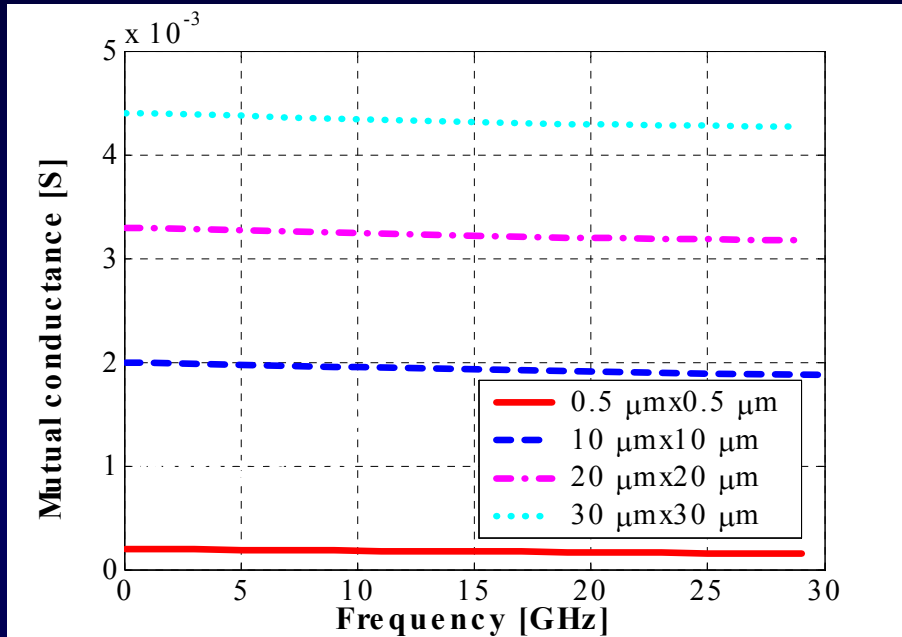

- Susceptance may be capacitive and/or inductive
- Mutual conductance less frequency sensitive than self conductance
- Conductance decreases with frequency in this case but increases in other cases

# Mutual Admittance Models

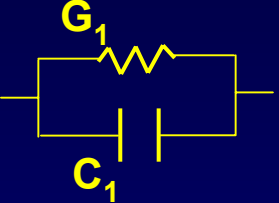
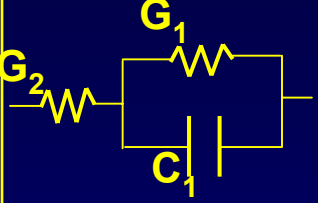
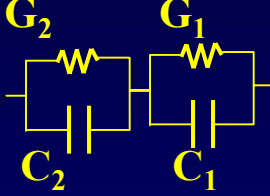
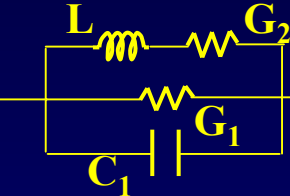
	Model 0	Model I	Model II	Model III	Model IV
Circuit					
Suitable frequency range	$f < 1\text{GHz}$	$1\text{ G} < f < 5\text{ G}$	$5\text{ G} < f < 10\text{ G}$	$f > 5\text{ GHz}$	$f > 1\text{GHz}$
Comments	Simplest low frequency model	Cannot model the frequency dependence of G. Capacitive coupling only	Models the frequency dependence of G and B. Capacitive susceptance	Similar to Model II but with better agreement with simulations	Suitable for both capacitive and inductive coupling. Very good agreement with simulations

- Model 0 through Model III are existing models
- Model IV proposed new model

# New Mutual Admittance Model and Simulations Comparison

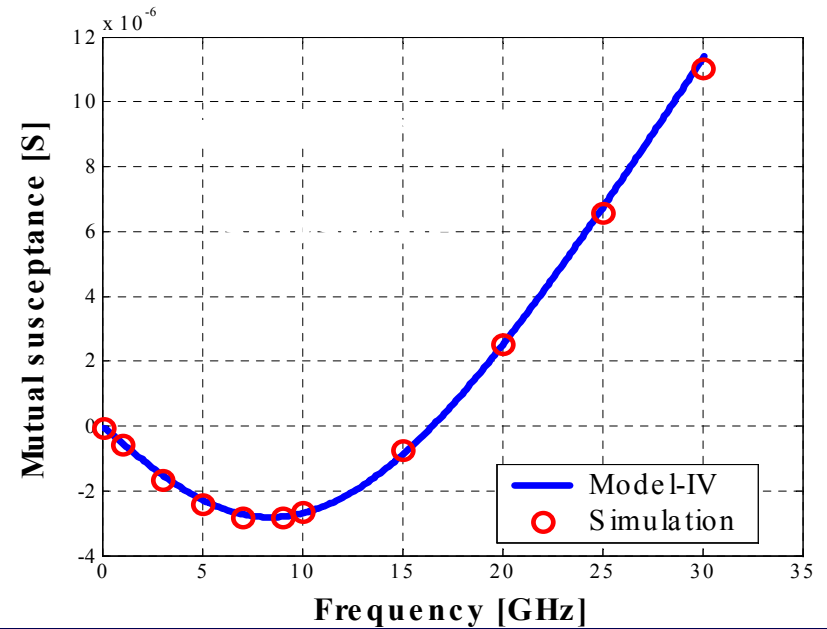
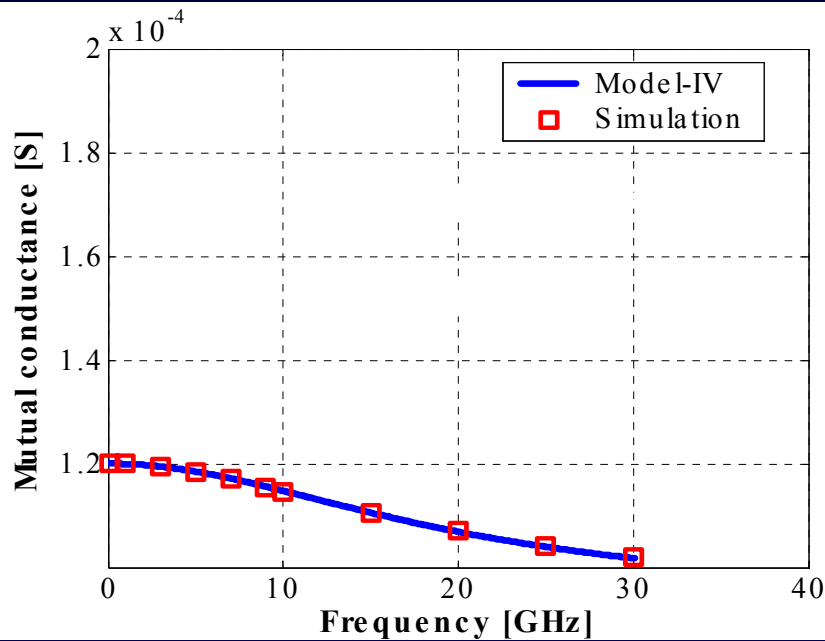

- Existing models can not be used if inductive behavior occurs

# Conclusions

---

- **Suitable frequency ranges for models have been identified**
- **Frequency dependence of self admittance differs from that of mutual admittance**
- **Proposed new self coupling and mutual coupling models**
  - ✓ **Better accuracy and larger suitable frequency range than that of existing models**
  - ✓ **Good agreement with numerical simulation results**
- ***Next step: Extend results to develop scalable high frequency substrate coupling model***