

Modeling and Simulation of a wireless sensor data acquisition system using PCM algorithms

Khalil Arshak

Dept. Electronic and Computer Eng
University of Limerick
Limerick, Ireland
khalil.arshak@ul.ie

Essa Jafer

Dept. of Electronic and Computer Eng
University of Limerick
Limerick, Ireland
Essa.Jafer@ul.ie

Declan McDonagh

Toumaz technology Ltd, Abingdon
Oxfordshire, OX143DB
UK
declan.mcdonagh@toumaz.com

ABSTRACT

This paper presents a novel simulated model for a wireless data acquisition system. The system will read analogue information provided by two sensors and can be used for medical purposes. Real data has been obtained and a simulation of the two signals coming from both pH and pressure sensors embedded in the system has been employed. The created model contains four main units simulated using SIMULINK. At the first unit, the output signal is encoded to digital signal based on adapting one of the Pulse Coding Modulation (PCM) algorithms. The second unit simulates the processor function that is responsible for framing, mixing and compressing the incoming bit streams from both sensors. The third unit, where the digital data is modulated and sent through different noisy channels, represents an efficient FSK transmitter/receiver model. At the receiver end, the signal is demodulated and processed inversely to extract the original analogue signal read by the two sensors.

In this work, the performance of the systems using different PCM methods will be studied comparatively in order to control the transmission and reduce the amount of data sent. This leads to a significant reduction in power consumption. In addition, efficiency of the RF channel in terms of Bit Error Rate (BER) and through different noisy conditions is investigated.

1. INTRODUCTION

Recent advances in integrated sensors have made a realization of smart microsystems combining a large mixture of micro-sensors and signal processing circuitries. This will have a significant impact on a variety of applications such as health care, consumer electronics, environmental monitoring and medical diagnosis [1,2].

Such systems are required to have many attributes, such as low cost, robustness and real-time data processing. The need for wireless communication is increased by the high cost of

wiring and the growing demand for distributed and remote sensing, data acquisition, and control. Sensor manufacturers are integrating RF systems in the same enclosure as their sensing devices. Wireless communication is a viable and cost-effective method of transmitting data over long distances, through electrically noisy environments. A number of telemetry-based medical systems have been developed for different implanted applications [3,4,5].

A general block diagram of a telemetry data acquisition system is depicted in Figure 1. It consists of analog stage, where a signal read by the sensors is recorded, digitally encoded where the signal will be converted to a bit stream, processor unit and the RF unit that combines both transmitter and receiver circuitry.

In this paper, a novel data acquisition system has been developed, simulated and tested. Pressure and pH sensors signals are employed for system performance assessment as they have a significant role in environmental monitoring [6]. Four algorithms have been introduced in the system to achieve high data compression; which will be presented in the next sections.

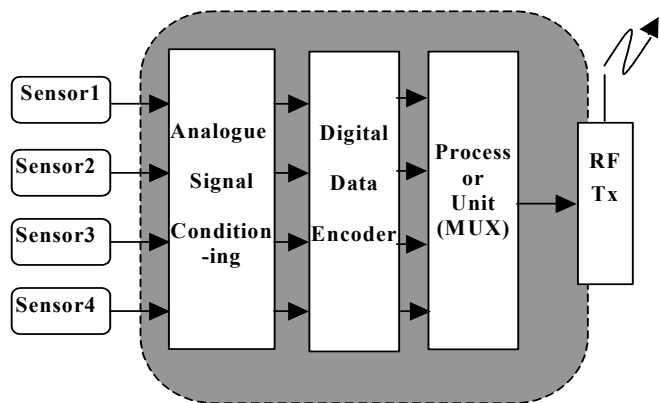

Figure .1. Block diagram of telemetry multisensor system

2. System Specifications

Figure.2 shows the main task and functions that should be implemented by the proposed system. In the first stage, two different analog signals obtained from a real data [7] are simulated and encoded into digital signal. The sources of the two signals are a pH and pressure sensors that have been used for medical applications. As shown in Figures 3 and 4, the rate of change of the two analog data are quite different, such that pressure signal is rapidly changing in a random way, while the pH taking a relatively stable values over a certain periods.

The system functions can be divided into four main stages. The output of the first stage is a digital encoded bit stream using a PCM algorithm as will be explained in the next section. The two binary data streams coming from the two channels are processed by the controller unit, which represents the second stage. The data coming from each channel is framed, multiplexed and compressed at this stage before it is sent to RF unit. At this stage, the serial binary stream will be modulated using FSK and sent through a noisy RF channel to the receiver. The data is then demodulated at the receiver side and inversely processed to recover the two analog signals. The PCM methods used in this system are the uniform quantization, nonuniform quantization, differential pulse code modulation and adaptive pulse code modulation.

The performance of the simulated system will be assessed in two stages. At first stage, the effect of data compression implemented by the controller unit and tested with the different PCM methods. Then the RF channel performance for a certain range of frequencies is investigated for different conditions.

3. Pulse Code Modulation Algorithms (PCM)

PCM is the most obvious method developed for digital coding of waveforms and it is often used for speech signals, which have a non-stationary nature. Essentially it refers to the process of quantizing the samples of discrete-time signal, so that both time and amplitude are represented in a discrete form. Three different PCM methods have been adapted in the proposed system, these are [8,9]:

3.1. Uniform Pulse Code Modulation (UPCM)

It is a digital representation of an analog signal where the magnitude of the signal is sampled regularly at uniform intervals of duration. Every sample is quantized to a series of symbols in a digital code, which is usually a binary code. A uniform quantizer with an even number of outputs values is employed in this method. For a uniformly distributed input variable x with standard deviation σ and zero mean, the probability density function (PDF) is:

$$f_x(x) = \begin{cases} \frac{1}{2\sqrt{3}\sigma}, & |x| \leq \sqrt{3}\sigma \\ 0, & \text{otherwise} \end{cases} \quad (1)$$

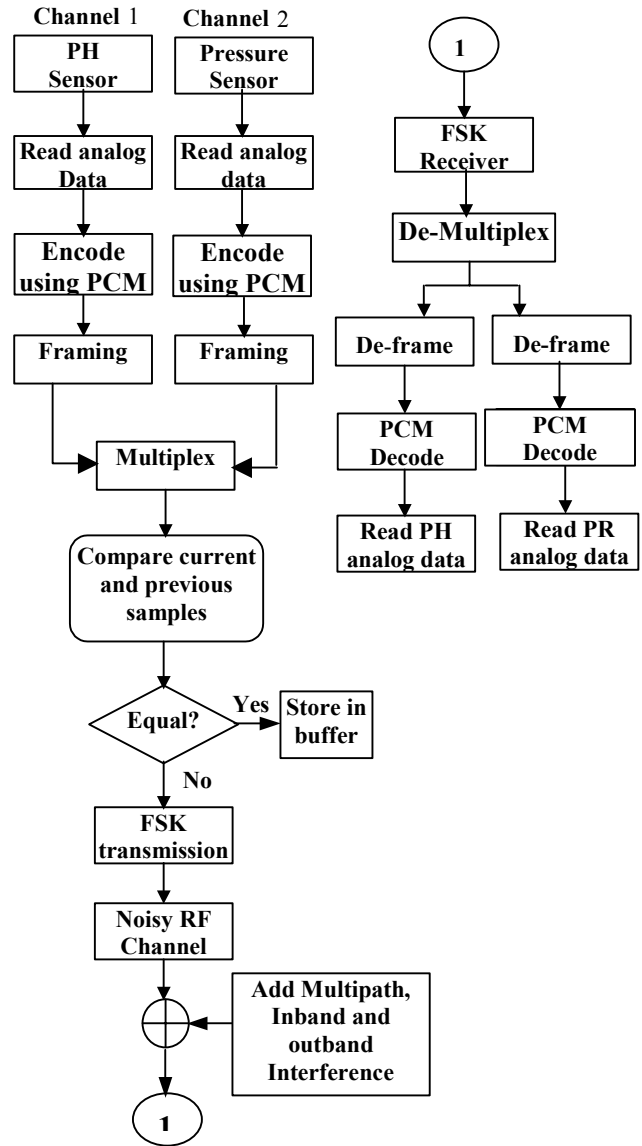

Figure .2. Description flowchart of the proposed wireless multi-channel system

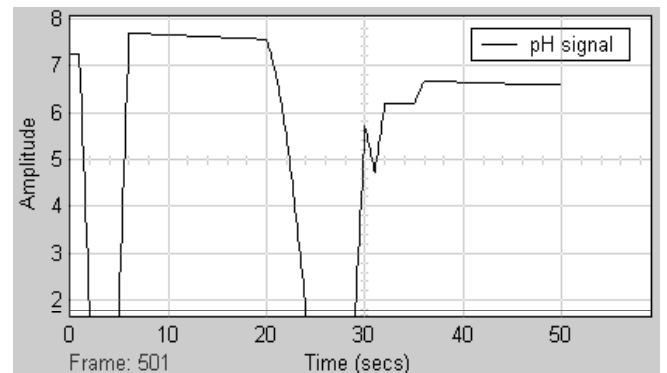

Figure .3. Simulated signal read by a pH sensor

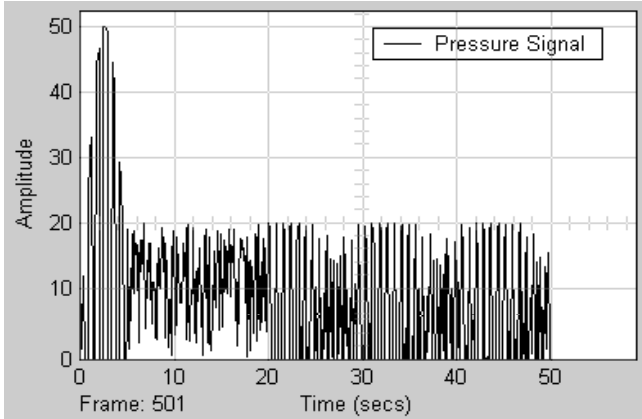

Figure .4. Simulated signal read by a pressure sensor

3.2. Nonuniform Pulse Code Modulation (NPCM)

For a nonuniform quantizer, the input is first transformed with a memoryless monotonic nonlinearity $f(\cdot)$ to produce an output $f(x)$. Then it is quantized uniformly with the quantized values transformed by the inverse nonlinearity. One of the two main logarithmic functions that have become widely used as design guidelines for non-uniform quantization, is the μ -law function, which is given by:

$$f(x) = A \frac{\ln(1 + \mu|x|/A)}{\ln(1 + \mu)} \text{sgn}(x), \quad |x| \leq A \quad (2)$$

Where A is the peak-input magnitude and μ is a constant that controls the degree of compression. The prevailing value used in practice is $\mu=255$.

3.3. Differential Pulse Coding Modulation (DPCM)

DPCM is based on the notion of quantizing the prediction-error signal. In many signal sources, samples are correlated with their neighbours, so the current sample can be easily predicted from the past history by forming the prediction-error signal. By quantizing the prediction error, a higher signal-to-noise ratio can be achieved for a given resolution. This method is presented in Figure 5, where the prediction error $e[n]$, obtained by subtracting the input $x[n]$ from the prediction $x_p[n]$, is quantized. The indices at the output of the quantizer's encoder represent the DPCM bit stream. The DPCM decoder works in a similar fashion to the encoder in order to obtain the quantized samples from the indices [8].

4. Simulation Of The Controller Unit

This unit has been modeled so that the following tasks can be achieved:

- 1-Framing the input coded bit streams coming from the PCM stage.
- 2-Control the operation of the RF transmitter/receiver by compress the amount of serial bits to be transmitted.

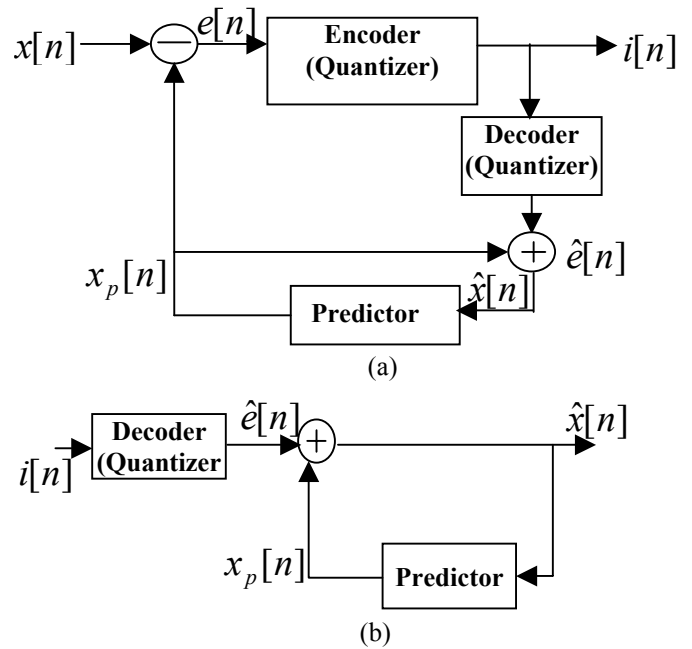

Figure .5. Differential Pulse coding (DPCM)

- (a) Encoder
- (b) Decoder

- 3- Mux the pH and pressure frames into a single frame with a start and end flag as shown in Figure 7.
- 4- Outputs a serial bit stream to the RF transmitter at a bit rate of 2.5 kbps.

A data compression mechanism based on sending only the unrepeated frames has been adapted. This will lead to reduce the amount of data bits to be transmitted and minimize the overall power consumption of the system. According to this, each frame may have one or more of the pH and pressure 8 bits fields to be filled with zeros.

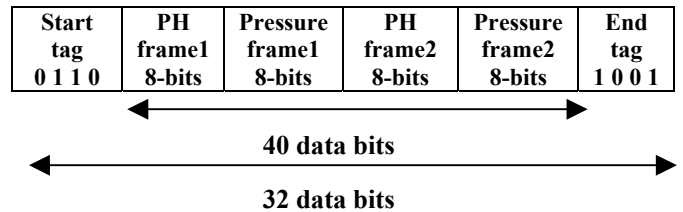

Figure .7. Output data frame of the processor unit

Figure 8 shows a two capture views of the output bit stream from the simulated processor unit. The time pause, where there is no transmission, can be noticed with different durations.

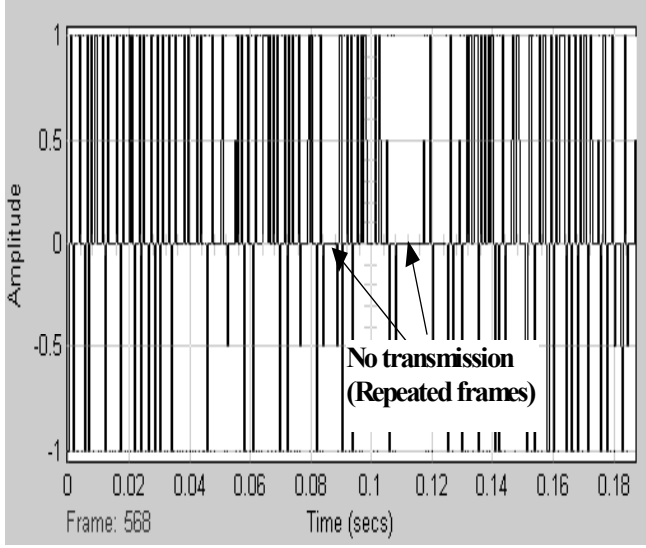

Figure .8. Sample of output data after compression

5. SIMULATION OF THE RF TRANSMITTER/RECEIVER

Wireless transmitters and receivers can be conceptually separated into baseband and RF sections [10]. Baseband is the range of frequencies over which transmitters take their input and receivers produce their output. The RF section of the transmitter is responsible for converting the processed baseband signal up to the assigned channel and injecting the signal into the medium. One of the main goals of the transmitter is to transmit a specified amount of power while consuming a little power as possible. Regarding the receiver design requirements, it must faithfully recover small signals and reject interference outside the desired channel.

RF systems are constructed primarily by using four basic building blocks; there are amplifiers, filters, mixers, and oscillators [11]. Figure 9 illustrates the architecture of the simulated direct transmitter/receiver using SIMULINK.

As can be seen from the figure, a voltage controlled oscillator (VCO) is employed in the transmitter side to modulate the incoming data. At the receiver, a two quadrature VCO's will be multiplexed with the modulated signal coming from the noisy RF channel and down convert its frequency using analog low pass filters. A logic detector will be used to determine the demodulated bit whether 0 or 1.

The output voltage signal from the transmitter VCO can be expressed as:

$$V_t = A \cos(w_{vco1}.t) \quad (3)$$

where w_{vco1} is a function of the input digital signal. The output voltage at the receiver side will be:

$$\begin{aligned} v_1 &= LPF\{A^2 \cos(w_o t) \cdot \cos(w_{vco1}.t)\} \\ v_o &= LPF\{A^2 \cos(w_o t + 90) \cdot \cos(w_{vco1}.t)\} \end{aligned} \quad (4)$$

Where w_o is the carrier frequency. v_1 and v_o are related to the input binary whether it is 1 or 0. The output voltage is shown to be linear with respect to the input voltage. Then a down conversion is occurred at the output of the LPF, where the frequency is:

$$v_1 \text{ or } v_o = \cos(w_{vco1} - w_o)t \quad (5)$$

The carrier frequency range considered in this system varies between 20-100MHz with a bandwidth of 20MHz, assuming a short range wireless transmission.

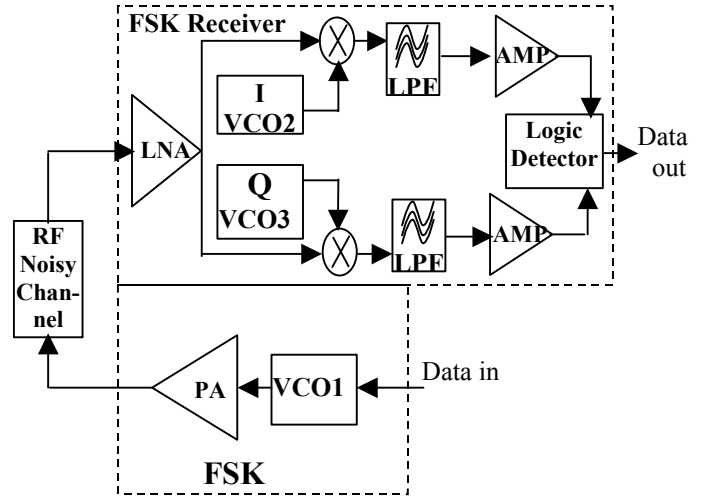

Figure .9. Structure of the simulated FSK transmitter/receiver

6. SIMULATION RESULTS

6.1 Testing PCM and compression mechanism

The performance of the compression implemented by the controller was assessed in terms of the total number of repeated and unrepeated frames that have to be sent to the receiver side. The three PCM methods were simulated initially at a rate of 1 Kbps. The output rate of the controller after framing and multiplexing is 2.5 Kbps. The results have been computed for both pH and pressure signals as shown in Tables 1 and 2 for total time of 50 seconds.

In general, it is obvious from the tables that the number of the unrepeated frames for the pressure signal is more than that for the pH, since the pressure is changing rapidly. This means that the current sample of the pressure signal is most likely to be dissimilar from the previous one. In contrast to the pH signal in which, the current will stay the same to the previous for a longer time intervals.

A good ratio was obtained by using NPCM, where the signal was first compressed by the μ -function before a uniform encoding occurs. Whereas DPCM has minimum compression ratio, since it is more sensitive to the

differential change between the current and previous samples.

Table 1: Compression performance for pH signal

PCM Coding algorithm (8 bits for sample)	pH Frames Sent	pH Frames Not sent	Compression Ratio %
UPCM	437	4849	91.73
N PCM	662	4624	87.47
DPCM	2588	2698	51.04

Table 2: Compression performance for pressure signal

PCM Coding algorithm (8 bits for sample)	PR Frames Sent	PR Frames Not sent	Compression Ratio %
UPCM	3036	2250	42.56
NPCM	480	4806	90.10
DPCM	3321	1965	37.17

The distortion has been measured between the original and recovered waveforms for both pH and pressure as given in Table 3.

Table 3: Distortion measure of the system output signals using the PCM methods

PCM Coding algorithm	pH signal Distortion	Pressure signal Distortion
UPCM	0.0104	0.0327
NPCM	0.8143	0.1309
DPCM	0.0284	0.1214

6.2. Testing the performance of the RF FSK transmitter/receiver

The FSK transmitter/receiver model was simulated and tested as its performance has a direct influence on the overall system operation. Sample of unipolar modulated and demodulated signals at carrier frequency of 100MHz are shown in Figure 10.

The performance of the model through RF channel with different noisy conditions was examined by estimating the average Bit Error Rate (BER) for the different PCM schemes. In addition, the effect of the compression mechanism implemented by the previous stage on the model was investigated. The considered range of transmission is varied between 20 to 100 MHz with a passband channel bandwidth of 20 MHz and a transmission bit rate of 2.5 Kbps.

Figures 11 and 12 show the BER simulation results using both UPCM and NPCM respectively. Basically the performance of the model has been improved for the two PCM methods by introducing the compression mechanism. The BER for the NPCM after 5 dB was greatly reduced by the compression. This is agreeing well with the results presented by tables 1 and 2, as the amount of data

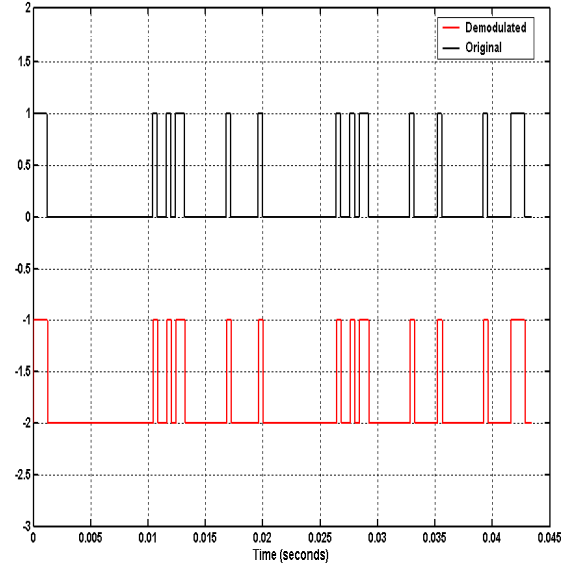

Figure .10. Original and demodulated using FSK receiver with a carrier frequency of 100MHz

compressed is much more less than for the other schemes. The same tests have been taken for the other PCM scheme as shown in Figure 13.

It is clear from the graphs that a slight improvement in BER is obtained when the DPCM is working in the compression mode. This was expected as the amount of data compressed or stored and not sent are much less for the two schemes. As a result of this, the distortion caused by using the DPCM on the recovered signal at the receiver side is smaller compared with the NPCM. However the UPCM proved to have a better performance in terms of the data compression and distortion effect.

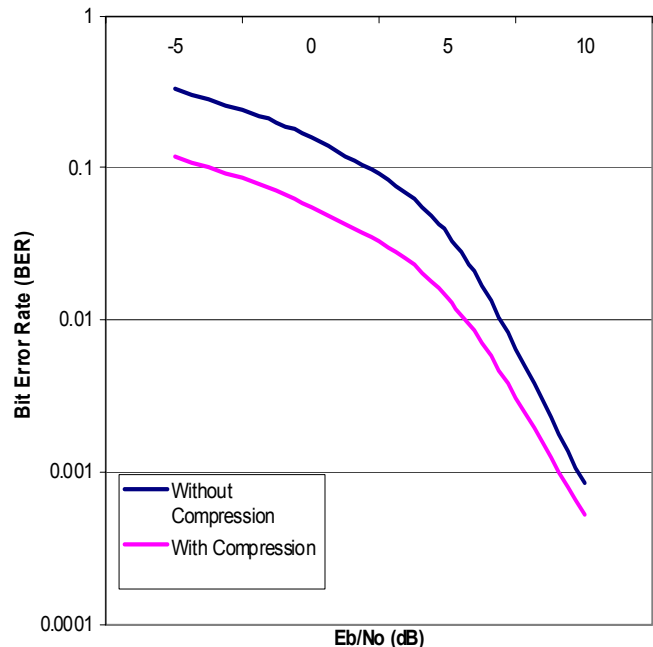

Figure .11. Simulated BER performance for FSK system using UPCM

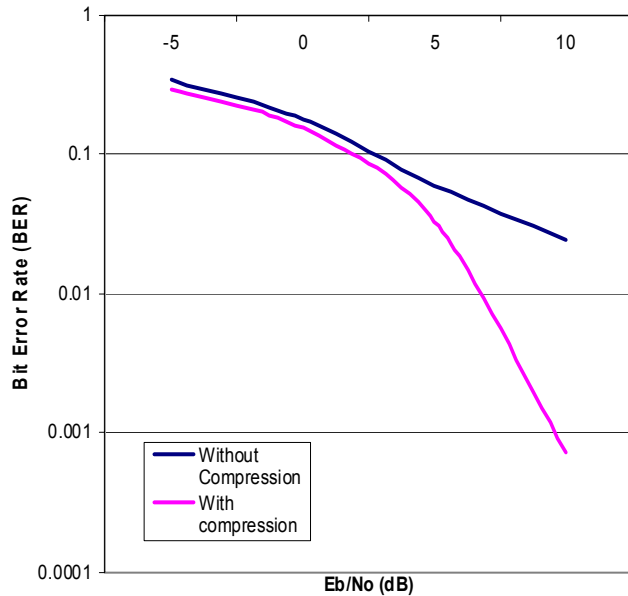

Figure .12. Simulated BER performance for FSK system using NPCM

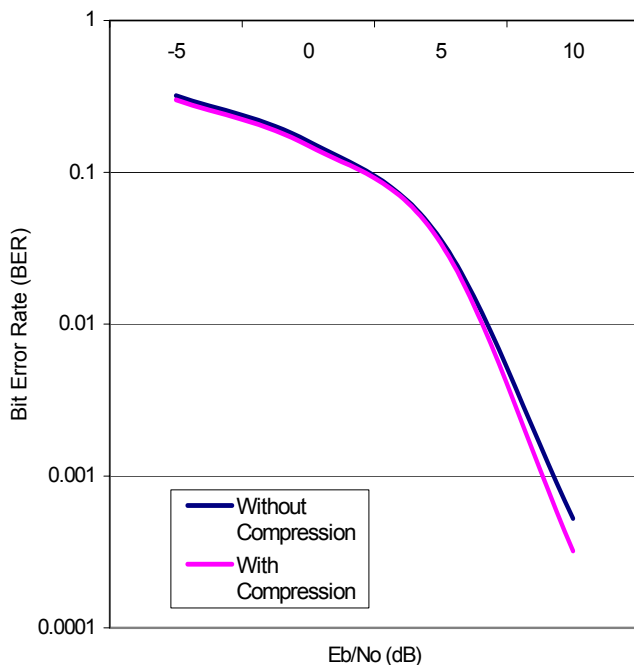

Figure .12. Simulated BER performance for FSK system using DPCM

7. CONCLUSIONS

In this paper, a novel model for a wireless sensor data acquisition system based on PCM schemes has been presented. The system mainly consists of four main stages. The function of each stage was verified and its relation to the other parts of the system was identified. Four different PCM schemes have been considered in this model.

At the simulated controller unit, a compression mechanism based on sending only the unrepeated frames has been

developed. Two real signals of the pressure and pH sensors have been employed in this model. Two main objectives were considered in this work, first the effect of using the four PCM methods on the overall system performance and the second is the influence of the compression applied by the controller on the data transmission through the RF channel.

From the presented results, a minimum distortion in the recovered signals in both, pH and pressure sensors were obtained by using the UPCM and DPCM.

Finally it was found that when the NPCM and the compression mechanism are used in combination, a significant reduction in the amount of data transmitted through the channel is obtained.

REFERENCES

- [1] Boon, T., Johannessen, E., Wang, L., Astaras, A., Ahmadian, M., Murray, A., Cooper, J., Beaumont, S., Flynn, B., and Cumming, D. R. S. Toward miniature wireless integrated multisensor microsystem for industrial and biomedical applications. *IEEE Sensors*, Vol No.6, 2002, pp. 628-635.
- [2] Mason, A., Yazdi, N., Chavan, A., Najafi, Wise, K. D. A generic multielement microsystem for portable wireless applications. *IEEE Proc*, Vol 86,1998, pp. 1733-1746.
- [3] Akin, T., Najafi, K., & Bradley, R. M. A wireless implantable multichannel digital neural recording system for a micromachined sieve electrode. *IEEE Solid State Circui*, Vol 33, No.1, 1998, 109-118.
- [4] Chatzandroulis, S., Tsoukalas, D., & Neukomm, A. A miniature pressure system with a capacitive sensor and a passive telemetry link for use in implantable applications. *IEEE Microelectromechanical Systems*, Vol. 9,No.1, 2000 pp.18-23.
- [5] Claes, W., Puers, R., sansen, W., De Cooman, Duyck, J., Naert, I. A low power miniaturized autonomous data logger for dental implants. *Sensors and Actuators*, Vol. 97-98,2002, pp. 548-556.
- [6] Wang, L., Tang, T., Johannessen, E., Astaras, A., Murray, A., Cooper, J., Beaumont, S., Cumming, D. R. S. (2002). An integrated sensor microsystem for industrial and biomedical applications. *Proc of the IEEE instrumentation and measurement technology conference*, Anchorage, USA, 2002, pp. 1717-1720.
- [7] Kumar, D., & Gustavsson, S. *An illustrated guide to gastrointestinal motility*. London: John Wiley & Sons, 1988.
- [8] Chu, W. C. *Speech coding algorithms*. USA: John Wiley & Sons, 2003.
- [9] Kondoz, A. M. *Digital speech*, Chichester: John Wiley & Sons, 1994.
- [10]Kundert, K. Introduction to RF Simulation and its application. *IEEE Solid-State*, Vol. 34, 2001, pp. 1298-1320.
- [11] Razavi, B. *RF Microelectronics*, NJ: Prentice-Hall, 1998.

ACKNOWLEDGMENTS

This work was supported by the Enterprise Ireland Commercialization Fund 2003, under technology development phase, as part of the MIAPS project, reference no. CFTD/03/425. Funding was also received from the Irish Research Council for Science, Engineering and Technology: funded by the National Development Plan.