



Functional Verification of Radio Frequency SoCs using Mixed-Mode and Mixed-Domain Simulations

Stefan Joeres, Prof. Stefan Heinen

Chair of Integrated Analog Circuits

Aachen University of Technology

<http://www.ias.rwth-aachen.de>

mailbox@ias.rwth-aachen.de



Outline

- Motivation
- Target
- Verification Problem in RF SoCs
- Baseband Modeling Basics
- Demonstration Example GSM Transceiver
- Simulation Results
- Future Desiresments
- Conclusions



Motivation

Modern transceiver systems feature:

- analog frontend
- digital enhancements
- digital calibration
- digital control loops
- digital predistortion
- digital interfaces
- digital programming

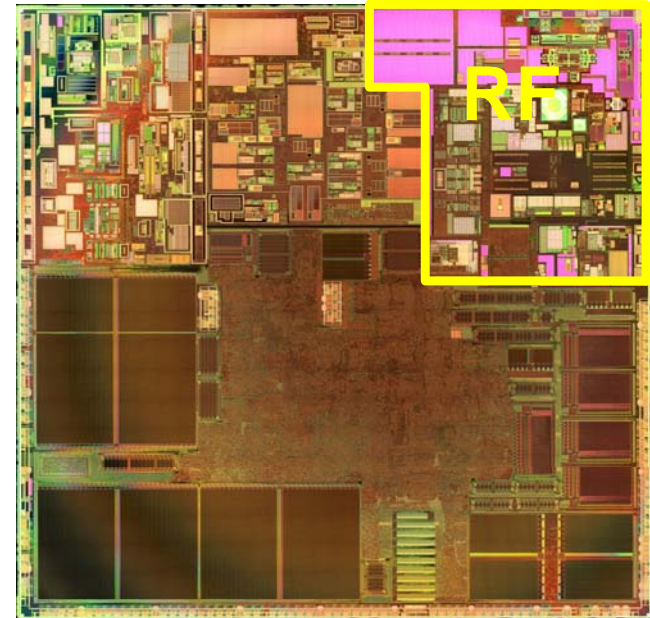

Several 100k gates are supporting and controlling the analog RF functions.

RF verification consumes lots of manpower & money.



Motivation

- **Tape – Out produces immense costs**
 - First time right
 - Mask set - about a million \$ for nano meter technologies
 - Wafer processing (time delay !)
- **Mistakes in complex systems are likely !**
 - Feedback between digital baseband logic and analog circuits (e.g. AGC, switchable filters, power up modes, PLL locking).
- **RF simulation speed is the bottleneck**



Targets

- **Short Term : Functional Verification of Tape Out DB**
 - Verify a complete transmission burst for different modes
 - Necessity to define a simulation strategy that covers all possibilities
 - Pin accurate compatible for all implementation levels !
 - Common database for verification and tape out
 - Just in time – always.
- **Long Term : Executable Specification**
 - Close the gap between
 - RF Engineer (Noisefigure, Gain, ...)
 - System Engineer (BER, PER, ...)



Verification Problem for Complex SoC

- **Simulation speed aspects**
 - A complete transmission burst including power up and bias settling is necessary (long transient).
 - Typical schematic of demonstration example (GSM Transceiver) on tape out database would take ~ 10 months to complete.
 - Traditional VerilogA model takes several days to complete
 - It is necessary to include the digital control logic and biasing structures.
 - Analog stepsize is inversely proportional to the highest frequency
- **Connectivity and functionality**
 - „Simply“ has to be ensured – more difficult than one may think...

Can We Speedup the Simulation?

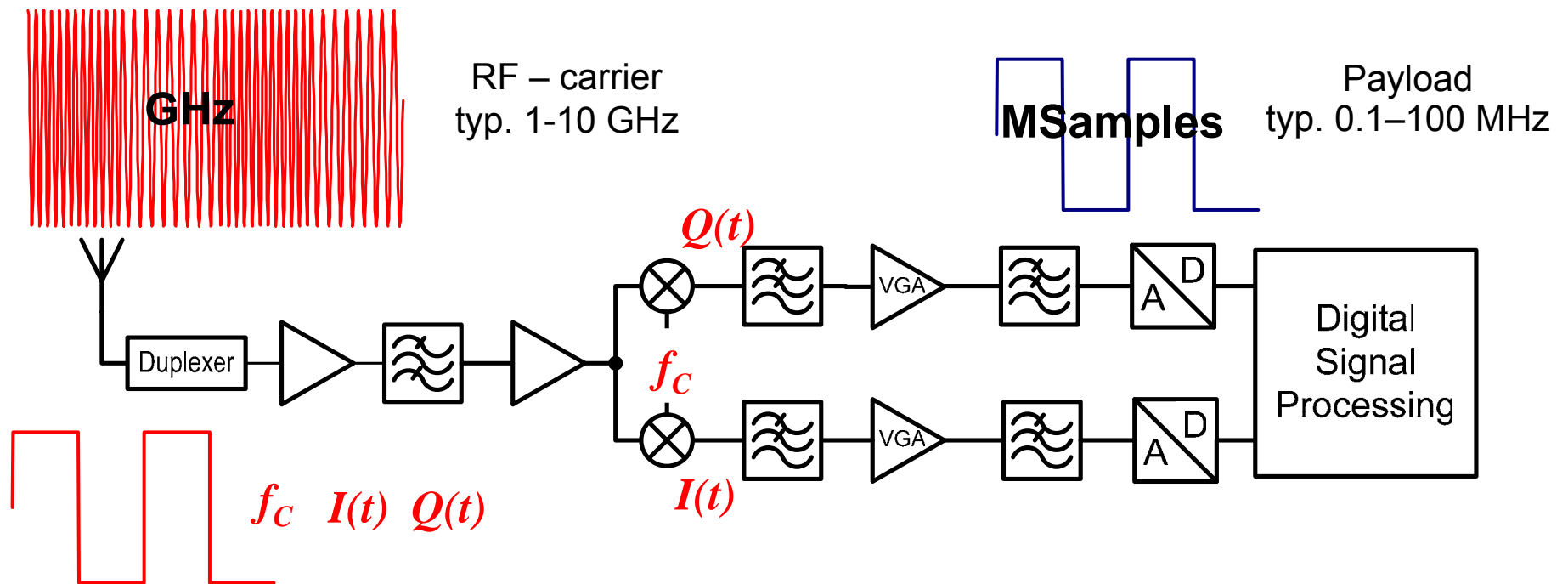

- Distortions, noise and signal combinations are the verification target.
 - Distortions of the RF-carrier itself don't have any information.
 - Only the distortions of the carried payload are relevant.

=> Baseband modeling omits the carrier frequency.



Baseband-Modeling

- RF Signal from a complex upconversion:

$$RF(t) = I(t) * \cos(2\pi f_0 t) - Q(t) * \sin(2\pi f_0 t)$$

- Equivalent, but complex baseband signal at the carrier frequency ω_c

$$B(t) = I(t) + jQ(t)$$

- Can be extended to frequency harmonics of the signal without increasing the bandwidth of each part through Fourier's Theorem. Rises number of nodes in signal path, but keeps low frequencies
- Main difference to standard behavioral modeling approach :
Abstract and complex signals demand for other models and for different connectivity structures between the blocks.
There's still nothing like a „struct“ or „record“ on analog toplevel to pass multiple data over single connect wire.



Baseband-Modeling

Connectivity problem for verification purposes



„Single Ended Schematic“
with real valued signals

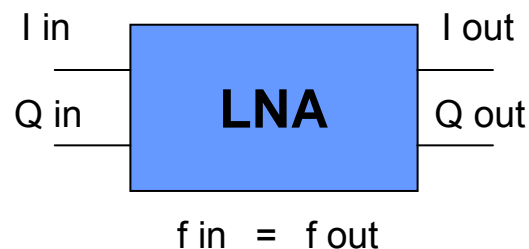

Equivalent baseband signal
needs (at least) two connections
(I,Q,f,harmonics,digital trigger,...)

=> New connectivity structures on simulation level are necessary !

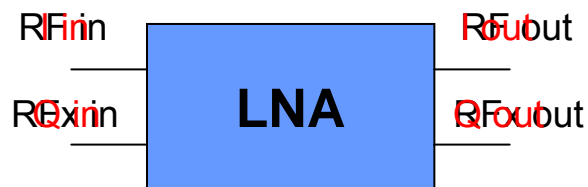

Workaround at present:
RF blocks typically have differential
wires that can be used

Demonstration Example

Commercial quad-band GSM transceiver
(Toplevel reduced for better display)

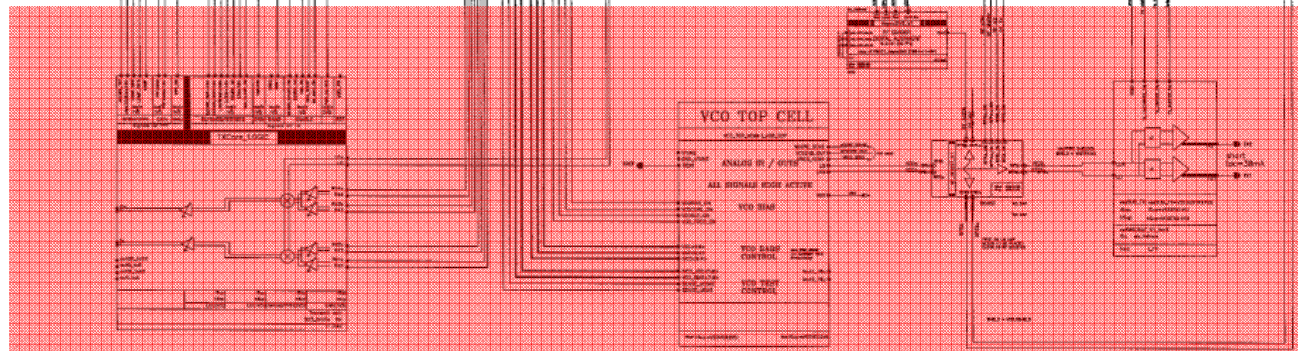
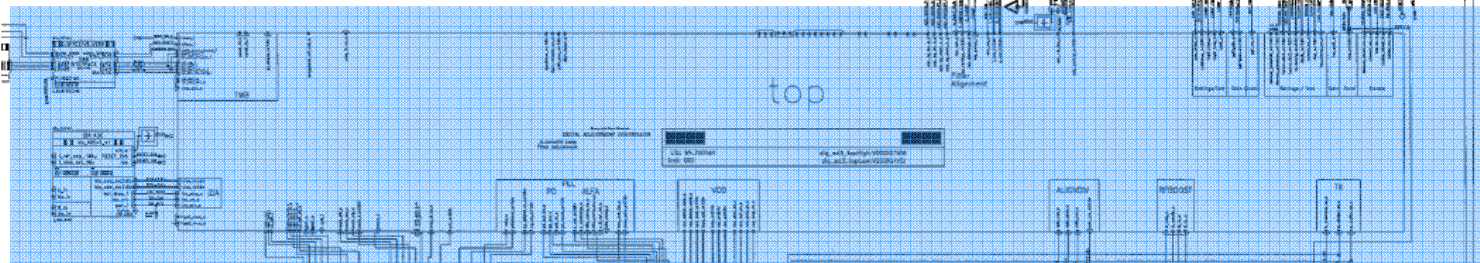
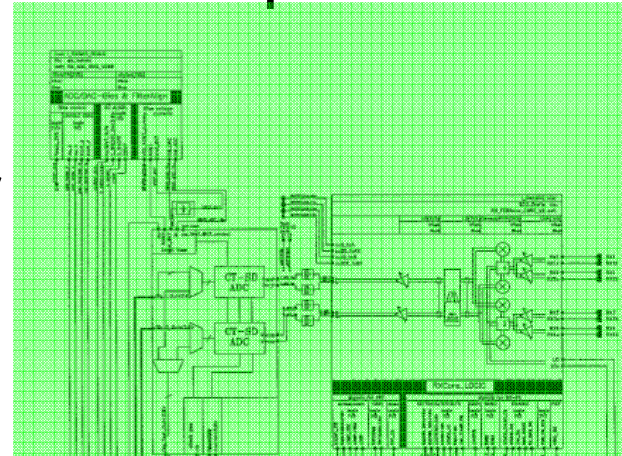

RX – RF Part

Digital Core Logic

Transmit & VCO Path

changed in V1_08
due to wide maci rules
Stehlecker 2005-02-11



Polyphasefilter Implementation

Different implementation variants are possible
(instantaneously switchable)

- a „near silicon“ schematic implementation with ideal or non-ideal opamps, that tries to match the real implementation as close as possible
 - an approximation with a „standard“ polyphase structure which just implements near correct corner frequencies and gain
 - an approximation as a true verilog modelling with parameters from the system designers
- ⇒ They differ more in simulation speed than in accuracy aspects arising from the number of equations to be solved.

Polyphasefilter Implementation (simple Schem)

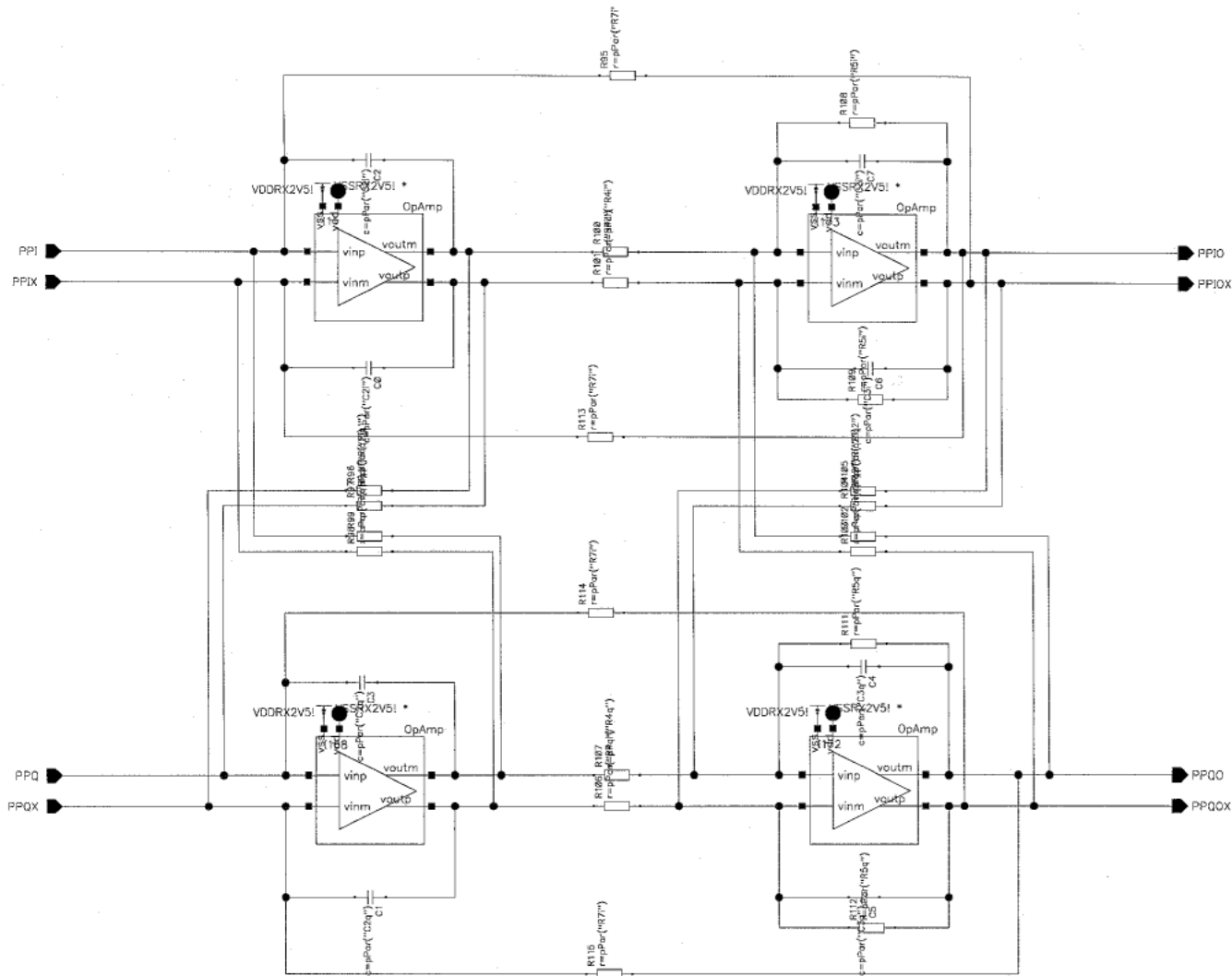



Polyphasefilter Implementation (VerilogA)

```

module PPF_V2(...);
[...]
analog begin
[...]
\\ A lot more stuff like VDD/VSS range checking, limitations, biasing, etc.pp.
[...]
    Isum=V(I_in)-V(I_out)-wM/w0*V(Q_out);
    Qsum=V(Q_in)-V(Q_out)-wm/w0*V(I_out);
    V(I_out) = laplace_nd(Isum,{1},{0,1/w0});
    V(Q_out)= laplace_nd(Qsim,{1},{0,1/w0});
end;

endmodule;

```



AC Simulation Times for PPF

- Original Schematic
 - 2297 nodes
 - 2348 equations
 - 459 s
- Simplified Schematic
(no control/adjustment)
 - 36 nodes
 - 43 equations
 - 8.28 s
- Verilog Modelling
 - 28 nodes
 - 53 equations
 - 5.5 s

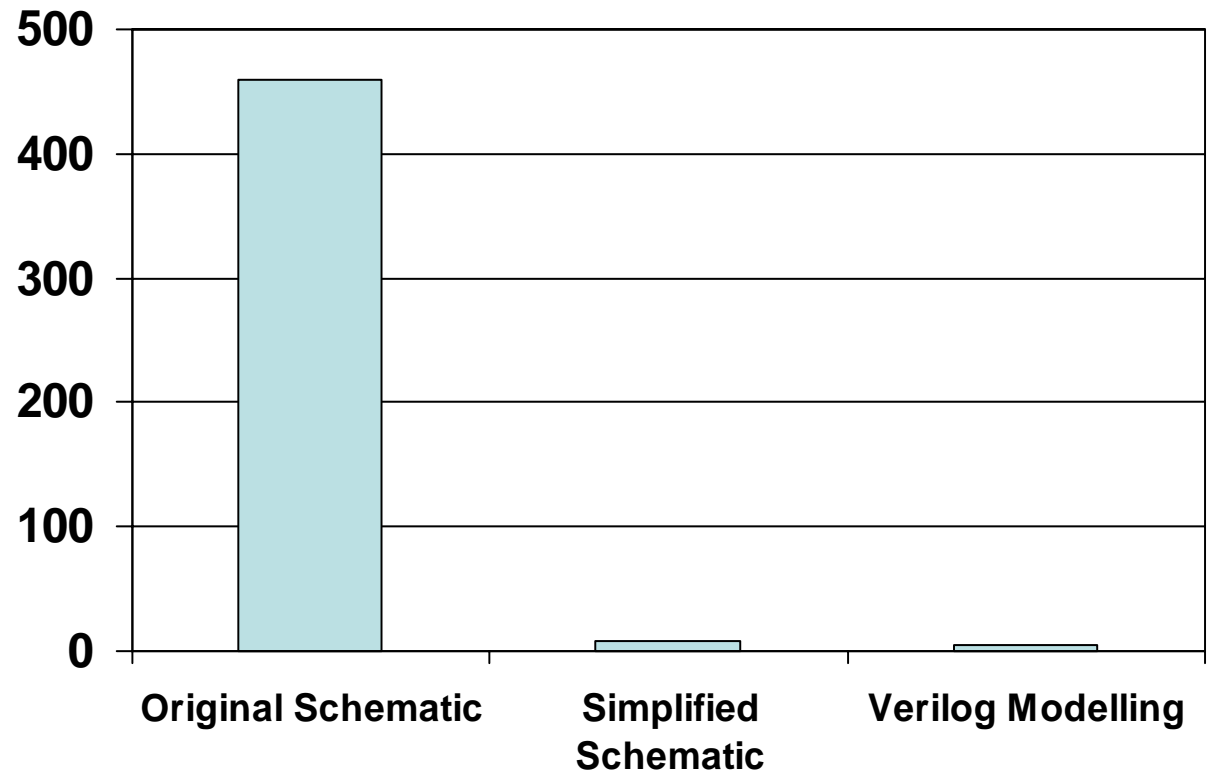

Performance Gain x 80



First Testbench description

- GFSK (or QPSK) signal source @ 850,900,1800 or 1900MHz
- low noise amplifiers
- mixers capable of mixing higher or lower sideband
- higher order polyphase filter
- Biasing structures
- **No ADC**

- ~ 13.000 Nodes
- ~ 16.000 Equations
- ~ 5.000 Transistors
- ~ 10.000 Caps
- ~ 10.000 Resistors



Implementation

- The RF-RX-part was implemented as pure VerilogA (although partly in VerilogAMS-Syntax)
- No clock necessary
- Pure analog signals and slow varying digital control logic
- RF frequency omitted through use of baseband models
- Simulation is therefore only in the analog domain, not event triggered

-> possible to simulate with pure spectre



Simulation Results RF-RX (no ADC, no digital part)

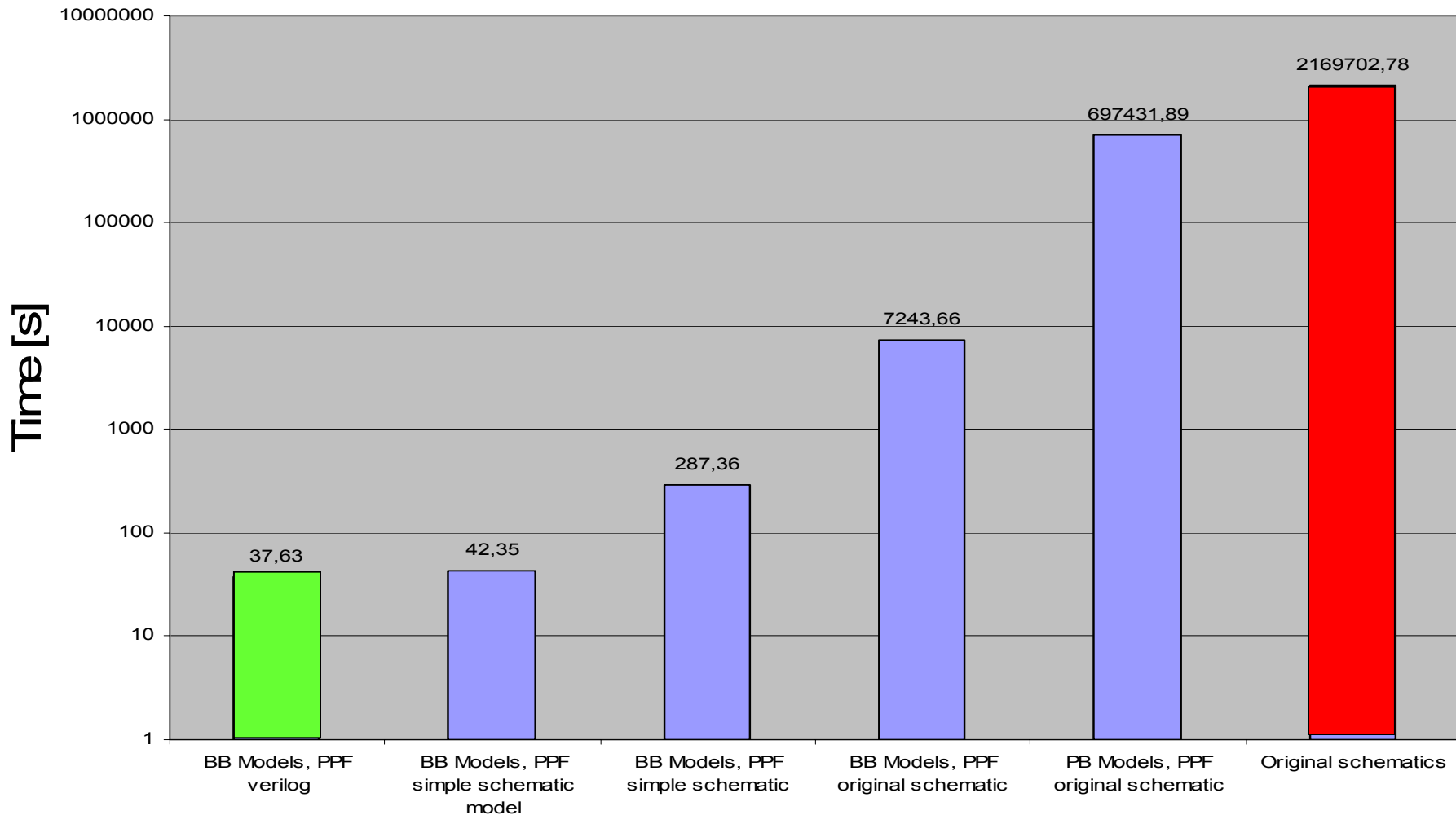

Performance Gain x 50000

Extending with digital logic and ADC

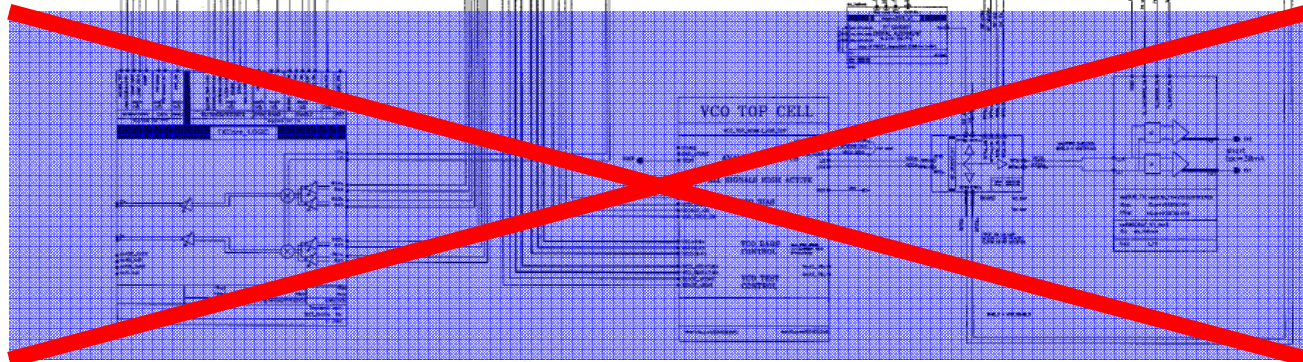
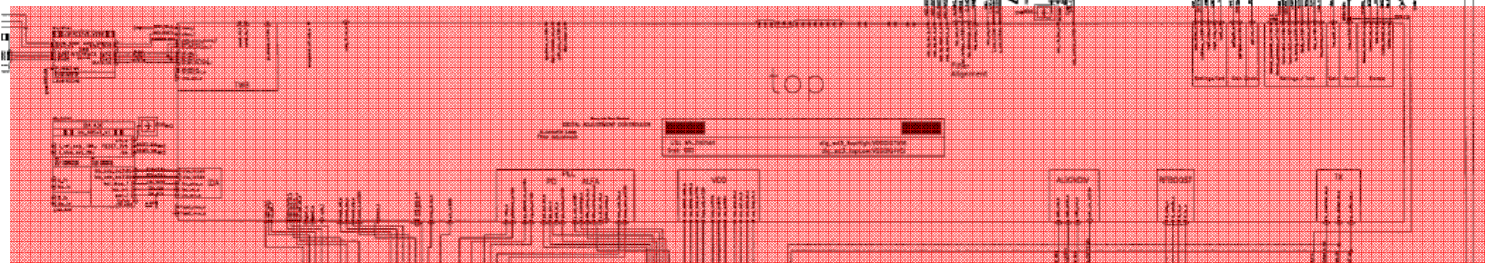
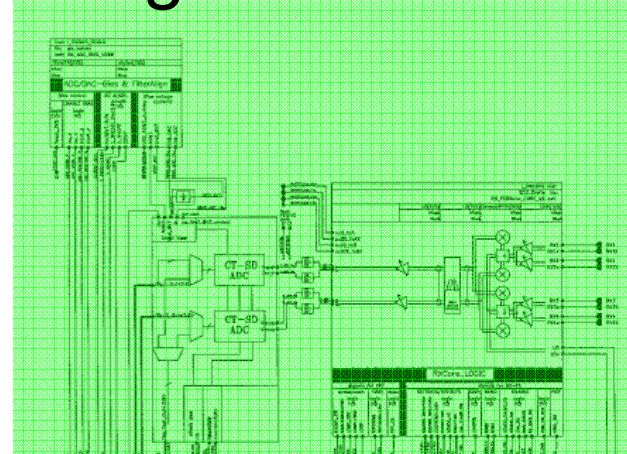

RX – RF Part

Digital Core Logic

~~Transmitter VCO Path~~

changed in v1_00
due to 4000 pin rules
Steinacker 2005-02-11



Complete RX System

- ~ 30.000 Nodes
- ~ 35.000 Equations
- ~ 23.000 Transistors
- ~ 21.000 Caps
- ~ 17.000 Resistors
- Digital part as VHDL-model with >10.000 parallel processes

Signal Flow and Possibilities

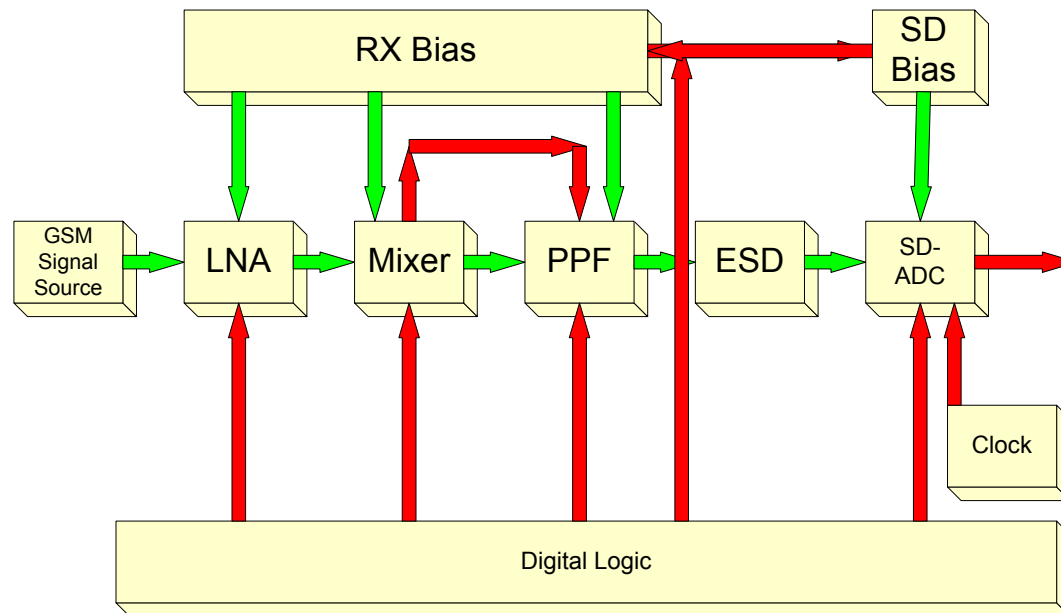

Possibilities:

Source : IQ Baseband (GFSK/QPSK)

LNA : schematic, IQ Baseband, RF Passband

Mixer : schematic, IQ Baseband, RF Passband

PPF : schematic, simplified schematic, verilogA

RX/SD Bias : schematic, verilogA

Digital Logic : VHDL, verilogAMS

Clock : analog, verilogAMS

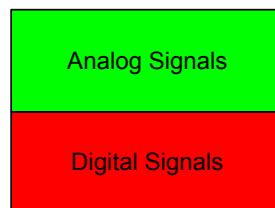



Simulation Results Complete RX

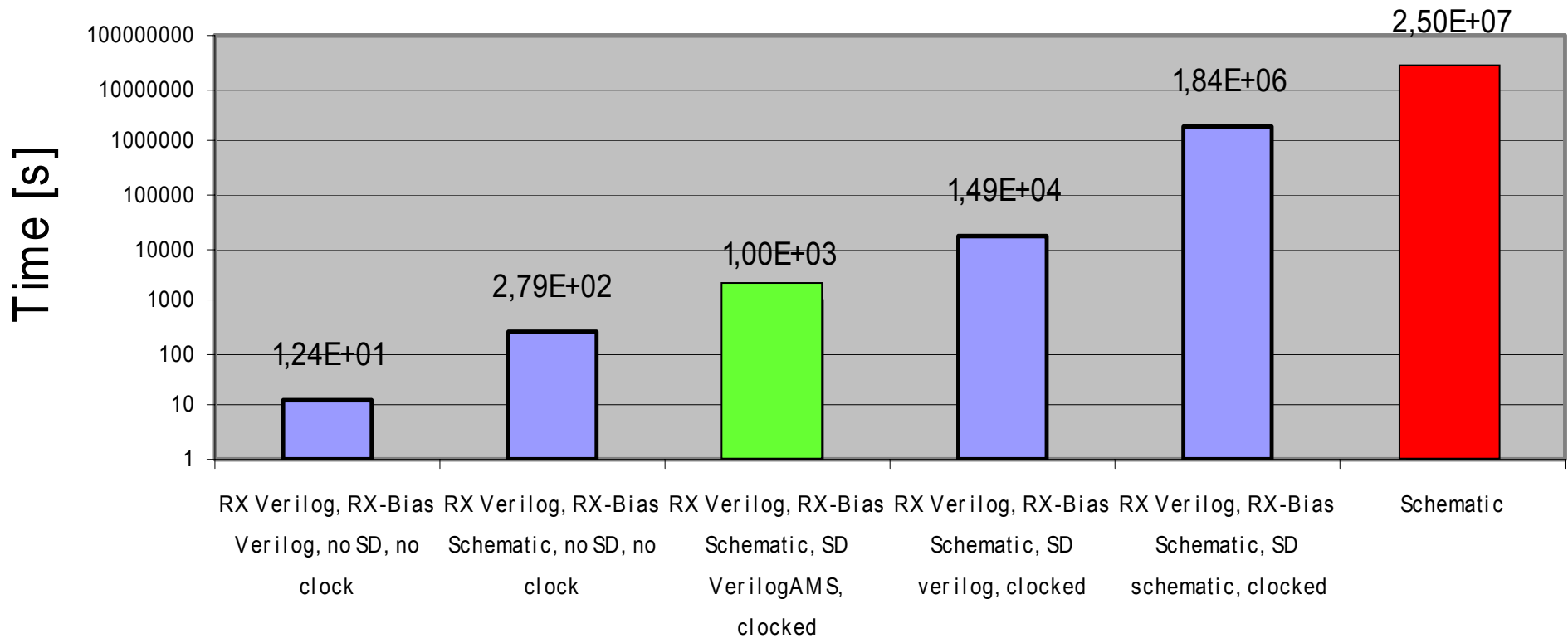

Performance Gain x 25000 (2.000.000 with simple ADC)



Simulation Profiles

	digital	analog	Cost function digital	Cost function analog
BB Modeling Transistorlevel - Bias	0.1%	99.9%	Connectmodules (7 %) VHDL core (6 %)	QPSK filter (2*0.6 %)
BB Modeling VerilogAMS - Bias	1.9 %	98.1 %	VHDL core(20%),	QPSK filter (2*1.8 %)
BB Modeling Verilog Bias Incl. ADC	3 %	97 %	VHDL core(6%), ADC (5%)	ADC (300%)

RF Simulation speed still is the bottleneck,
but at least the verification is possible !



Simulation possibilities

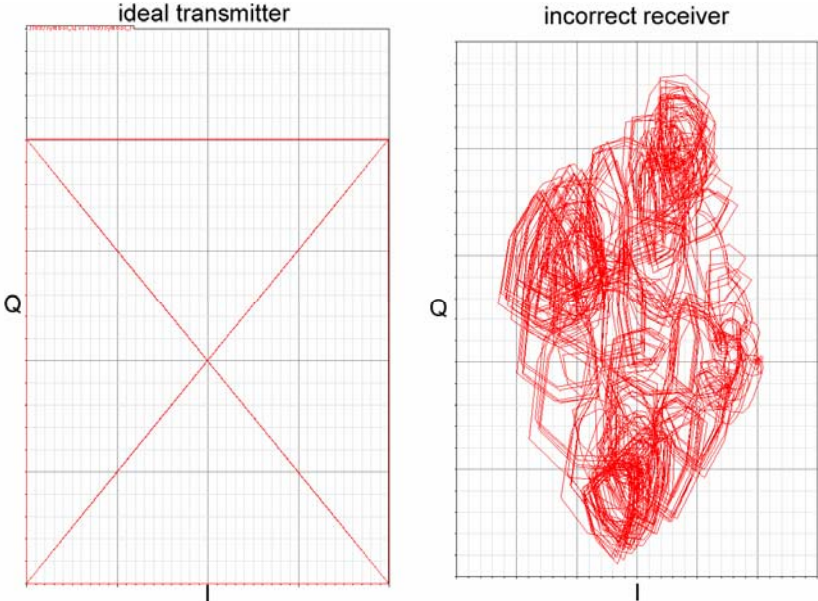

Accidentally twisted IQ path

Fast and effective I/Q verification

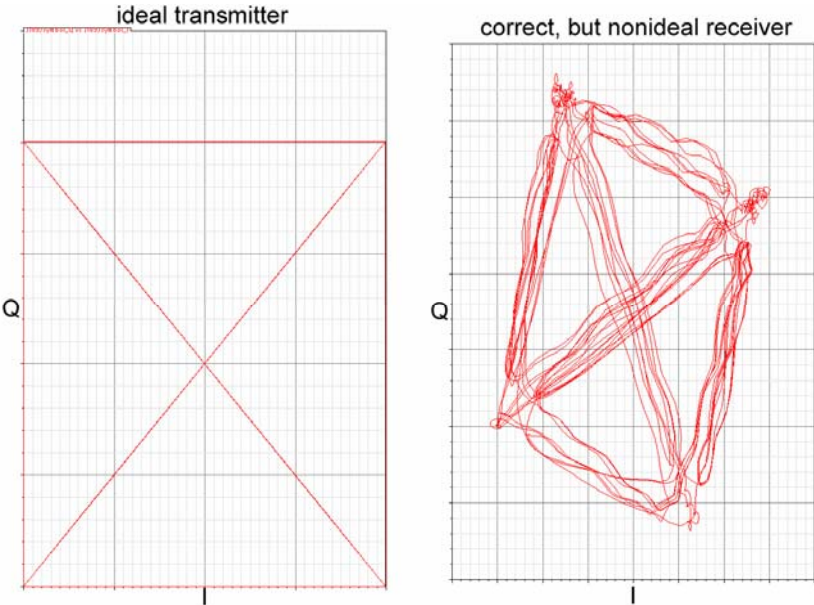



Limitations of actual implementation

- Only simple real values are passable between the modeling blocks
- Abstract datatypes for connectivity approved simulation on toplevel are required to enable
 - Easy to go baseband modeling
 - LO influence on mixer (I, Q, f, PN, harmonics)
 - Harmonics for mixing and conversion effects
- Example and demands are already at EDA R&D
- System Verilog promises interesting variants
 - Access by name / access by task would enable mixed BB/PB simulations without taking care of switching the full chain.
 - SystemVerilog AMS would really be great ...



Conclusion

- A GSM RX path has been modeled using baseband behavioral description approaches.
 - Functional verification prior to Tape Out was completed in ~ 16 min, including clocked SD-ADC
 - Included in this verification
 - Signal flow (Constellation plot with QPSK signal)
 - PU/PD modes
 - Frequency select
 - Sideband select
 - Gain settings
 - Biasing on transistor level
 - Digital Core