

# Behavioral models of Frequency Pulling in Oscillators

**M. Esmaeil Heidari, A. A. Abidi**

Electrical Engineering Department  
University of California, Los Angeles

# Pulling, useful and harmful effects

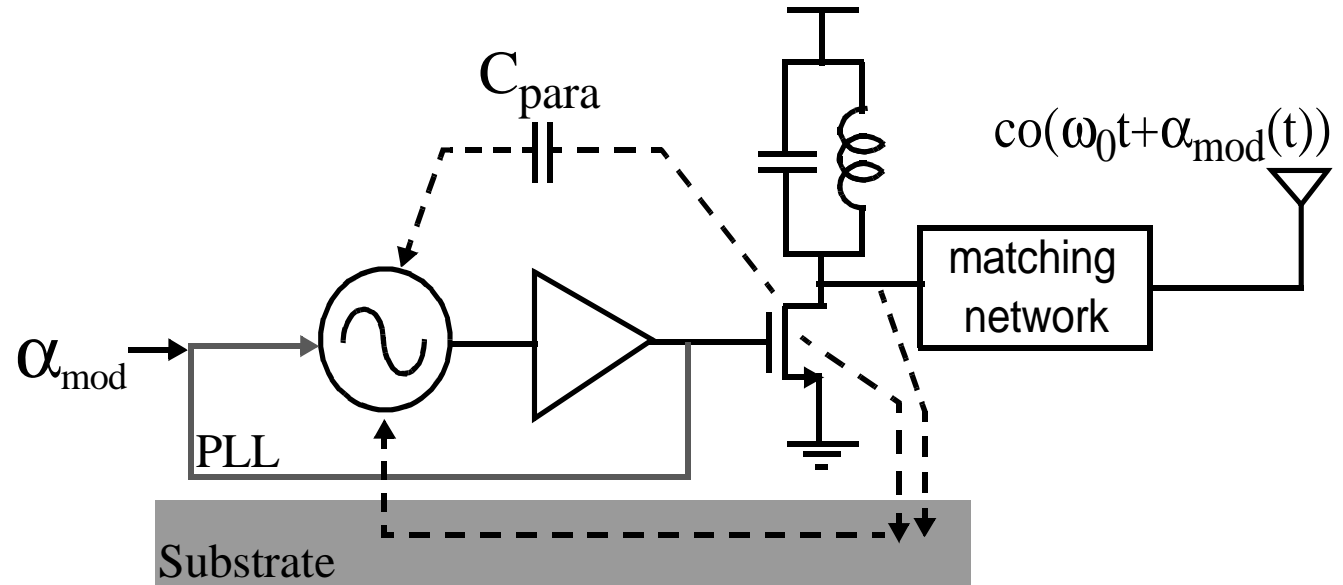
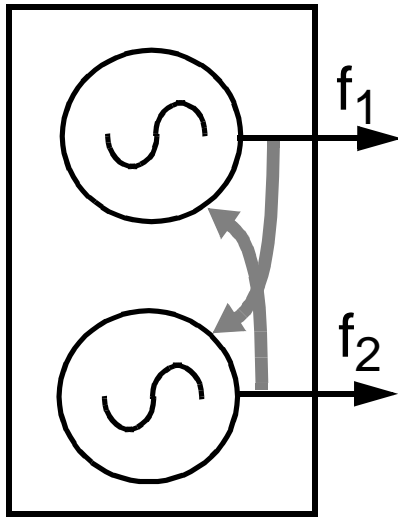

## Examples of pulling:

- Synthesizer
- Transmitter
- Quadrature Oscillator

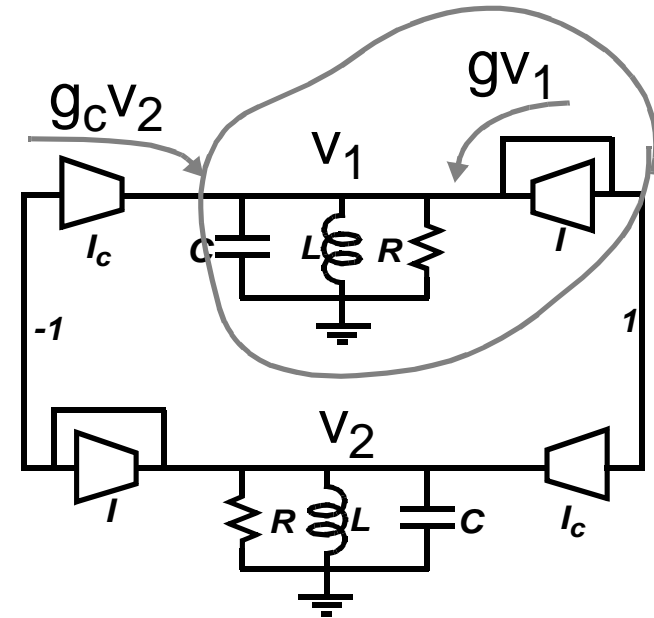

# Pulling in an LC oscillator, Adler's equation

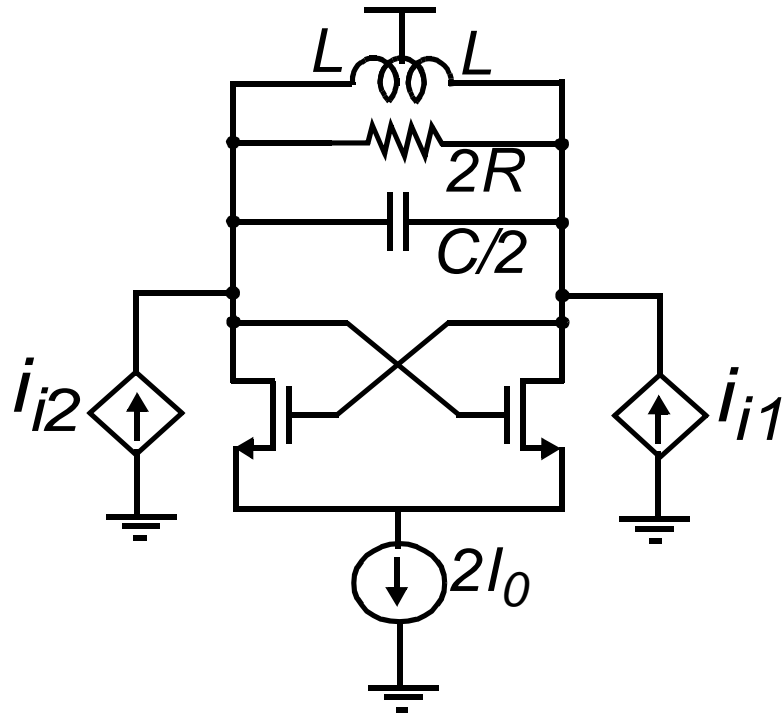

*KCL at output:*

$$\frac{v}{R} + \frac{1}{L} \int v dt + C \frac{dv}{dt} = I_i \cos(\omega t) + I \cos(\omega t + \theta)$$

$$i_i(t) = I_i \cos(\omega t) \quad v(t) = v_e(t) \cos(\omega t + \theta)$$

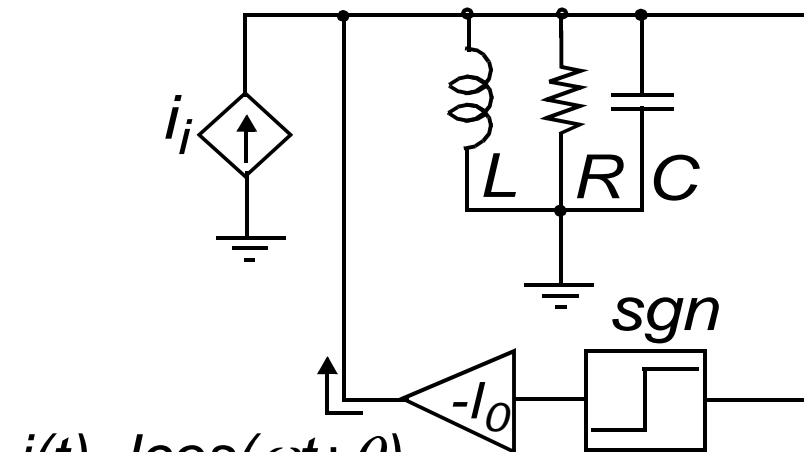

$$i(t) = I \cos(\omega t + \theta)$$

$$I = (4/\pi) I_0$$

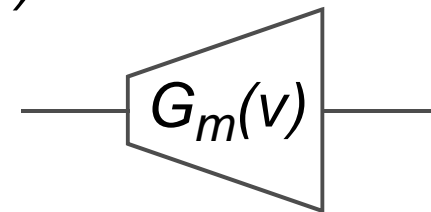

$$i_{out} = G_m(v) = G_{m0} v - \alpha v^3$$

# Pulling in an LC oscillator, Adler's equation

$$i_i(t) = I_i(t)e^{j\omega t} \quad v(t) = v_e(t)e^{j\omega t} e^{\theta} \quad i(t) = I(t)e^{j\omega t} e^{\theta}$$

$$\frac{1}{R} \frac{dv_e}{dt} + j\frac{1}{R} \left( \omega + \frac{d\theta}{dt} \right) v_e + \frac{1}{L} v_e + C \frac{d^2 v_e}{dt^2} + j2C \left( \omega + \frac{d\theta}{dt} \right) \frac{dv_e}{dt} + jC \frac{d^2 \theta}{dt^2} - C \left( \omega + \frac{d\theta}{dt} \right)^2 v_e = j\omega I_i e^{-j\theta} + jI \left( \omega + \frac{d\theta}{dt} \right)$$

$$\frac{1}{R} \frac{dv_e}{dt} + \frac{1}{L} v_e + C \frac{d^2 v_e}{dt^2} - C \left( \omega + \frac{d\theta}{dt} \right)^2 v_e = I_i \omega \sin(\theta)$$

$$v_e \approx RI = QL\omega I \quad I_i \ll QI$$

$$\frac{d\theta}{dt} = \omega_0 - \omega - \frac{\omega_0 I_i}{2QI} \sin(\theta)$$

$$\omega_L = \frac{\omega_0 I_i}{2QI}$$

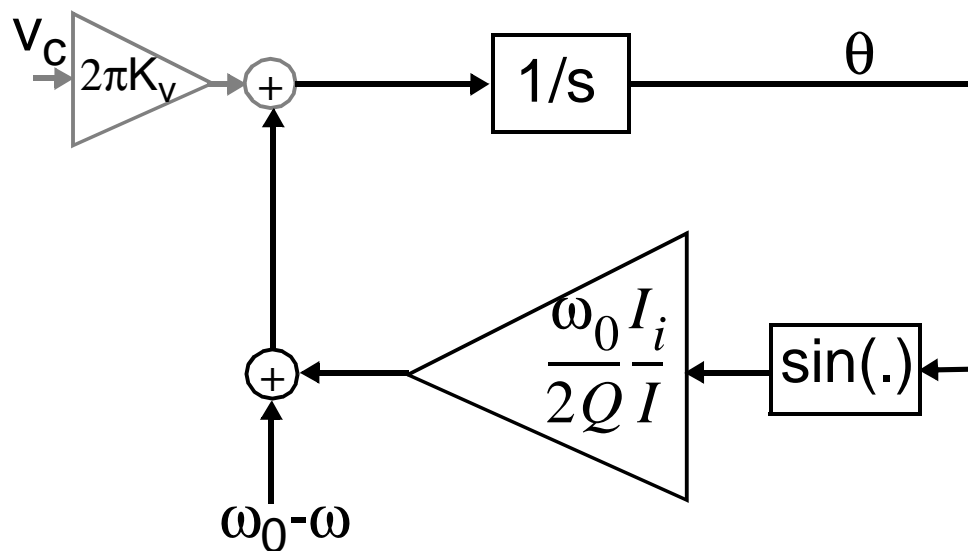
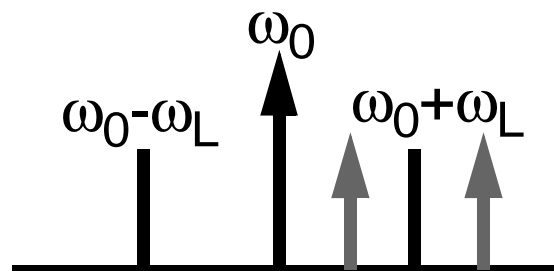

# Singal flow graph of an LC oscillator

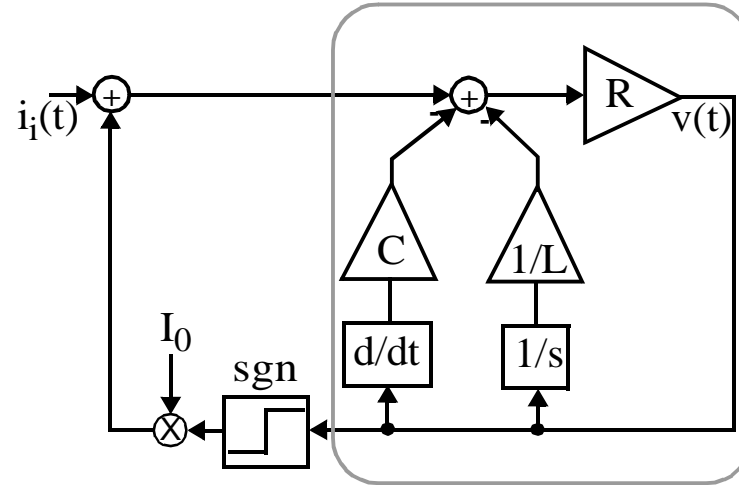
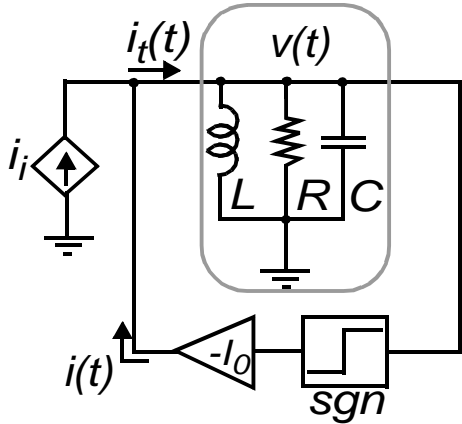

$$\frac{1}{L} \int_{-\infty}^t v(t) dt + C \frac{dv(t)}{dt} + \frac{v(t)}{R} = i_t(t) \quad v(t) = R \left[ i_t(t) - \frac{1}{L} \int_{-\infty}^t v(t) dt - C \frac{dv(t)}{dt} \right]$$

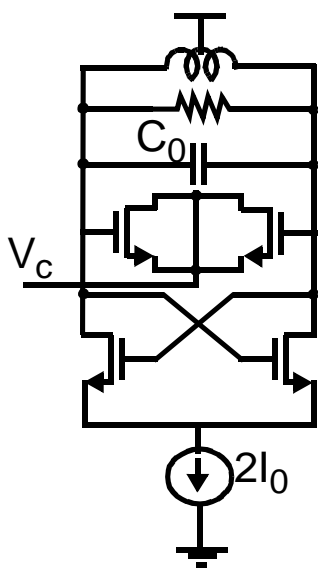

$$C_{\text{tot}} = C_0 + C(V_c)$$

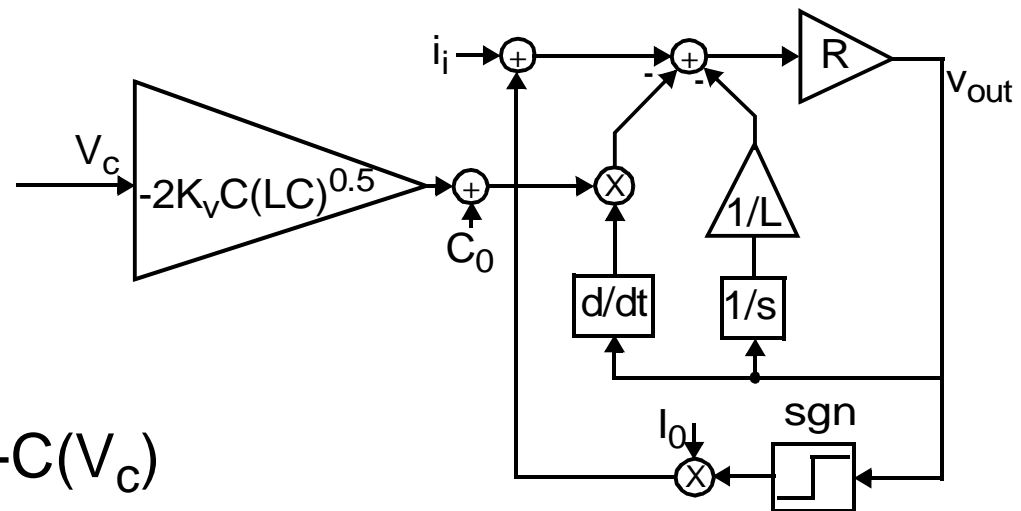

# Experimental validation

B. Razavi, "A study of injection locking and pulling in oscillators"

$$\frac{d\theta}{dt} = \omega_0 - \omega - \frac{\omega_0 I_i}{2QI} \sin(\theta)$$

$$\omega_L = \frac{\omega_0 I_i}{2QI} = 2\pi \times 1.5 \text{ MHz}$$

$$\omega_{osc} = 2\pi \times 900 \text{ MHz} \quad \frac{I_i}{I} = -38 \text{ dB}$$

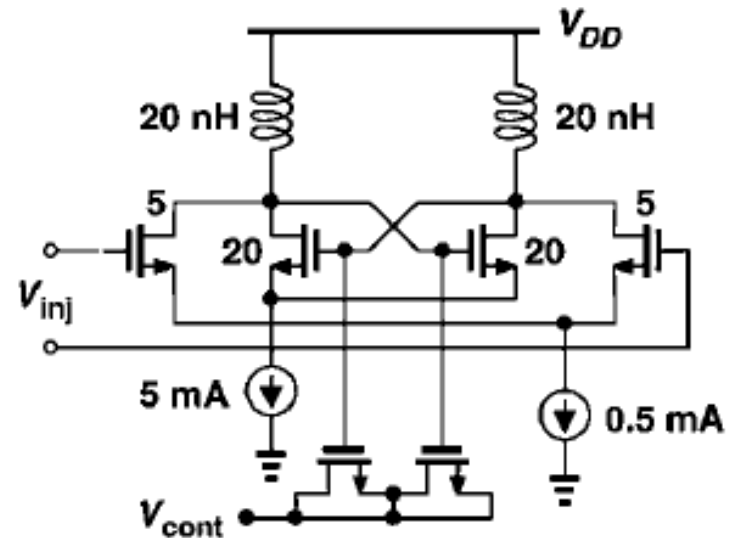

losc=2.5e-3; % tail current  
 F0=1e9; % nominal oscillation frequency  
 Fosc=992936860; % actual oscillation frequency  
 % measured under "no-pulling" condition

Flock=1.5e6; % lock range  
 linj=losc/80; % linj(dB) = losc(dB) - 38

Qtank= 5.8; % Quality factor of inductor  
 Ltank = 20e-9; % inductor  
 Rtank=Qtank\*Ltank\*(2\*pi\*F0); % parallel resistor of tank  
 Ctank=1/(Ltank\*(2\*pi\*F0)^2); % capacitor

Tstep=(1/F0)/200; % time step of simulation  
 Tmax=(2^21)\*Tstep; % simulation time  
 Finj=Fosc-Flock-710e3; % frequency of injected signal

sim('simulink\_model\_of\_osc',Tmax)

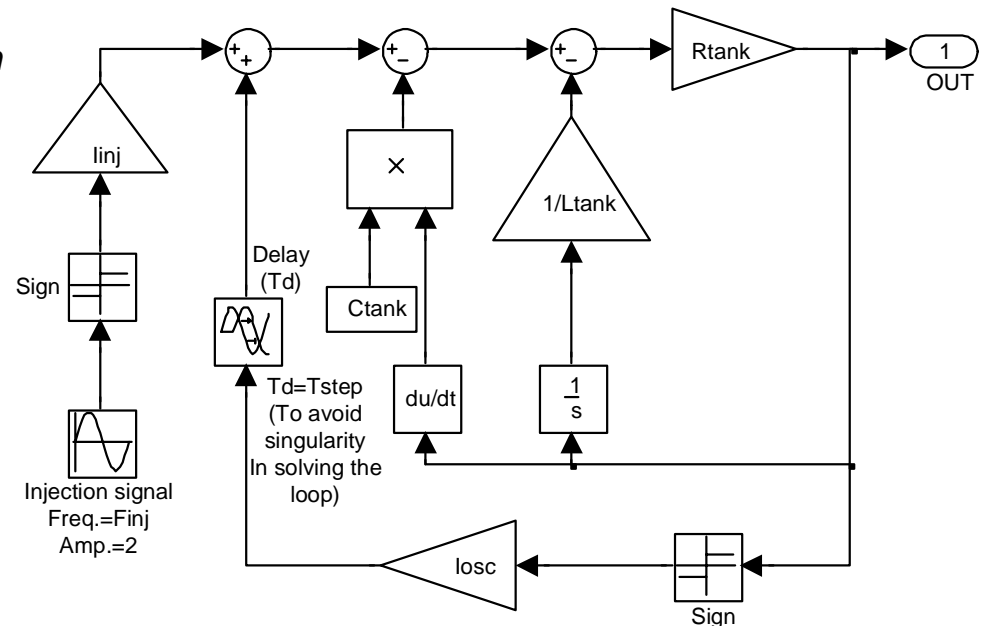

# Simulation vs. Measurement

$f_{inj}=110\text{kHz}$  out of lock range

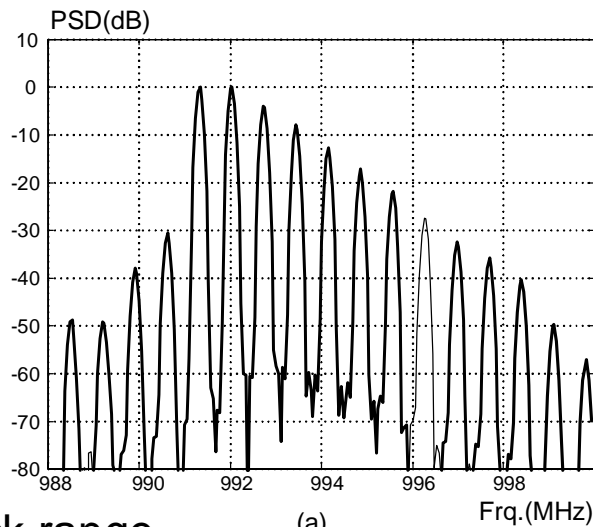

(a)

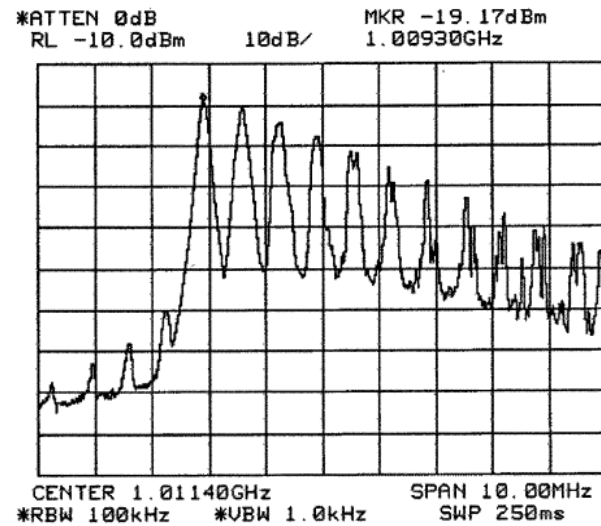

(a)

$f_{inj}=710\text{kHz}$  out of lock range

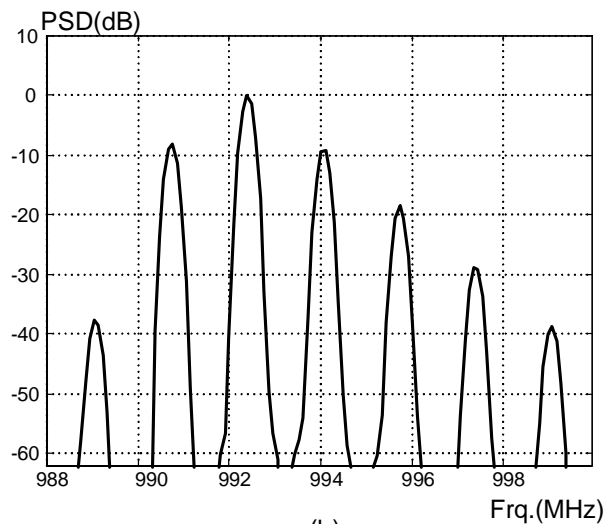

(b)

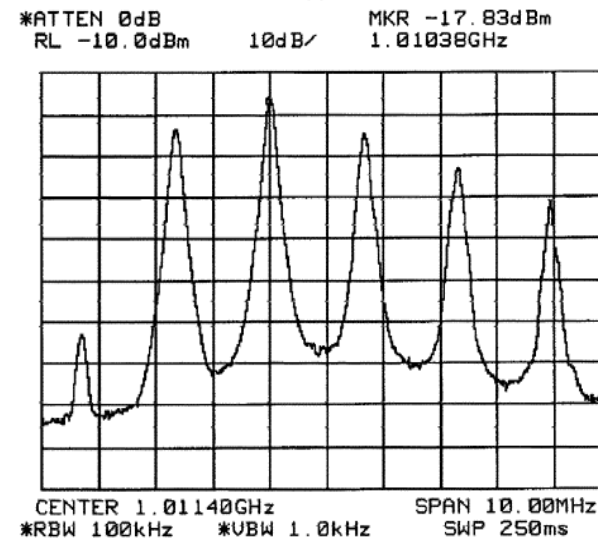

(b)

# Simulation vs. Measurement

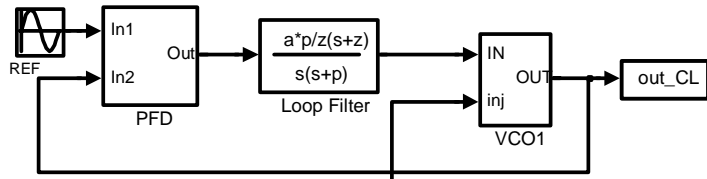

$F_{ref} = F_{osc}$   
 $F_{osc} = 0.929 \text{ GHz}$   
 $I_{inj} / I_{osc} = -40 \text{ dB}$

open loop

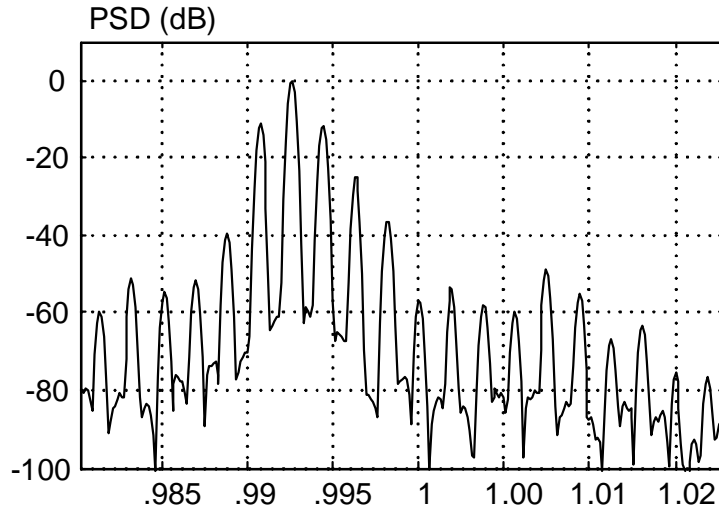

closed loop

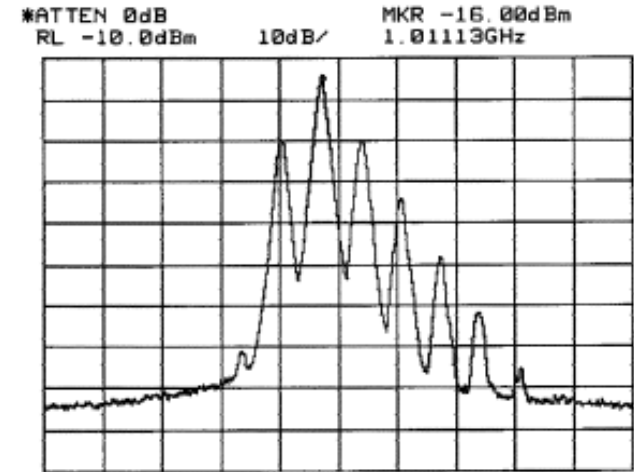
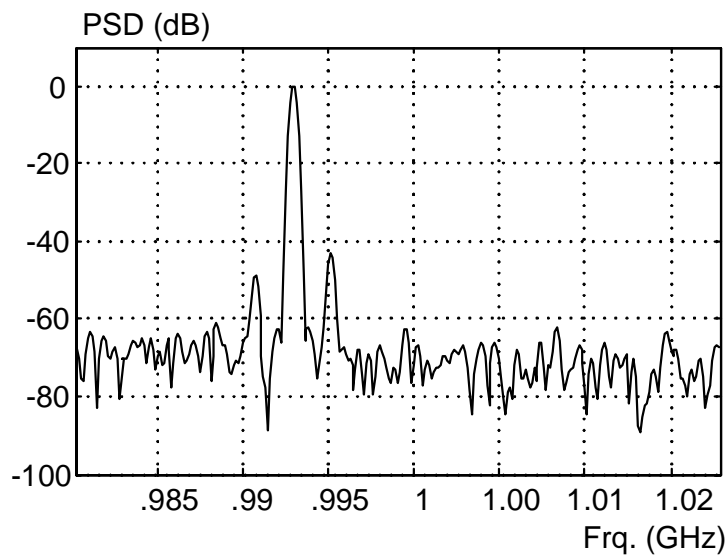

\*ATTEN 0dB  
 RL -10.0dBm  
 10dB/  
 MKR -16.00dBm  
 1.0113GHz  
 CENTER 1.01140GHz  
 \*RBW 100kHz \*UBW 1.0kHz  
 SPAN 10.00MHz  
 SWP 250ms

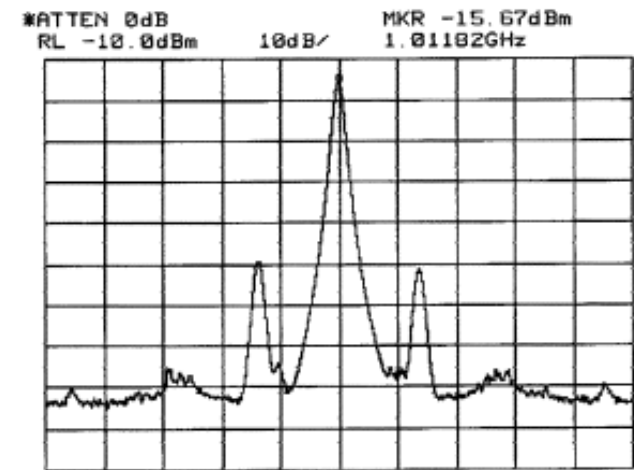

\*ATTEN 0dB  
 RL -10.0dBm  
 10dB/  
 MKR -15.67dBm  
 1.01182GHz  
 CENTER 1.01182GHz  
 \*RBW 100kHz \*UBW 1.0kHz  
 SPAN 10.00MHz  
 SWP 250ms

# An Example: Outphasing transmitter

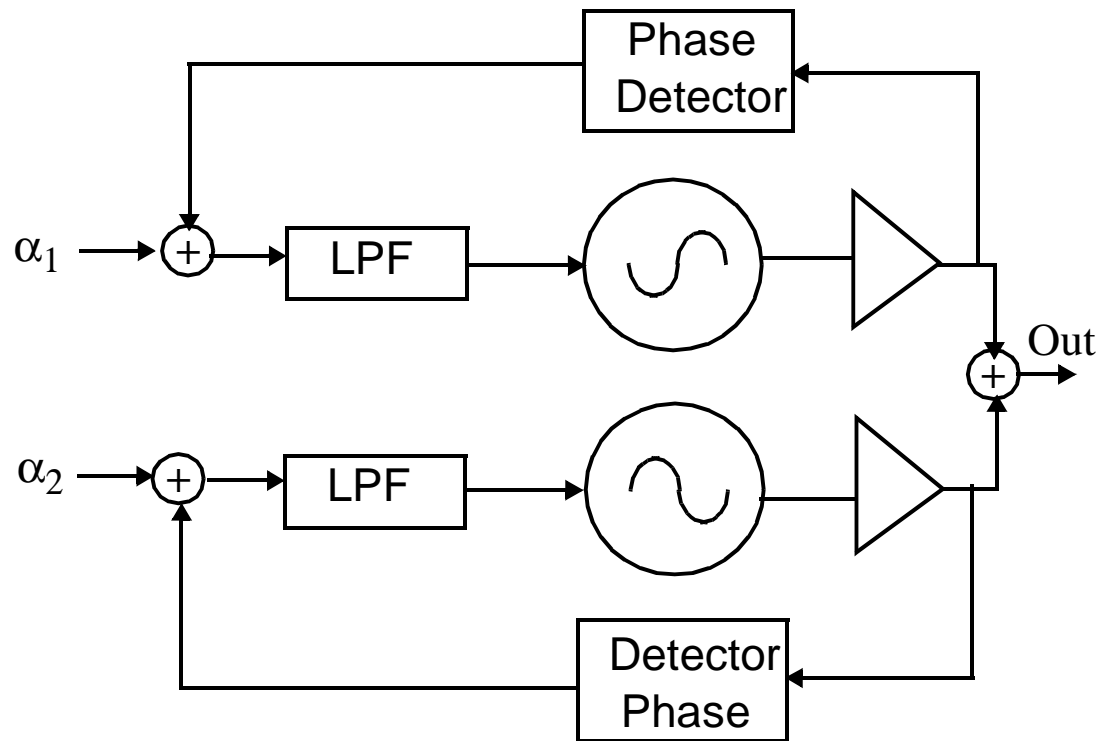
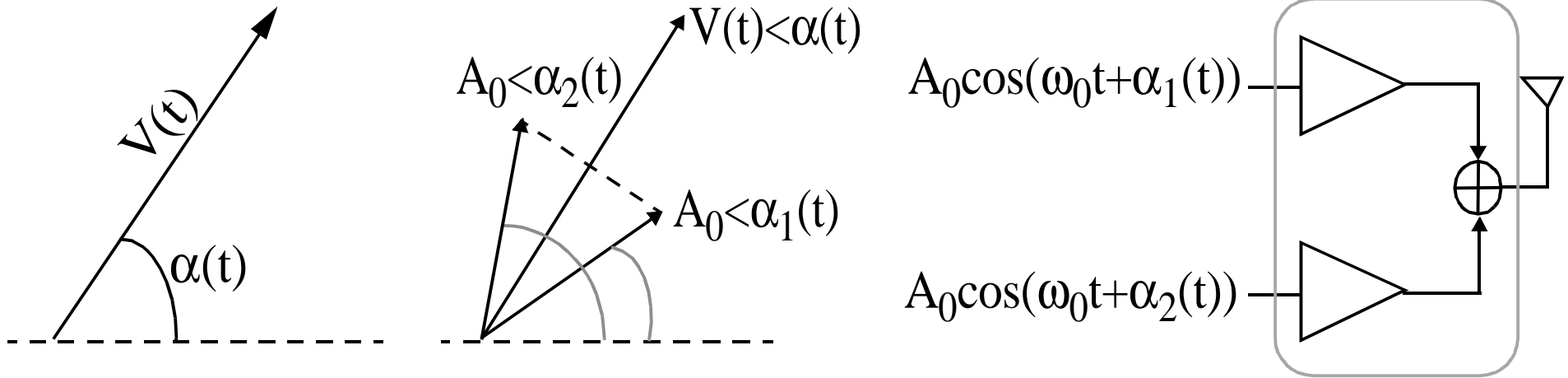

# Behavioral model for Phase Detector

REF is reference of time

This reference shows itself as  $T_0$  in the figure.

Output is phase of the **Clk** with respect to the reference signal and sampled at rising edges of the **Clk**

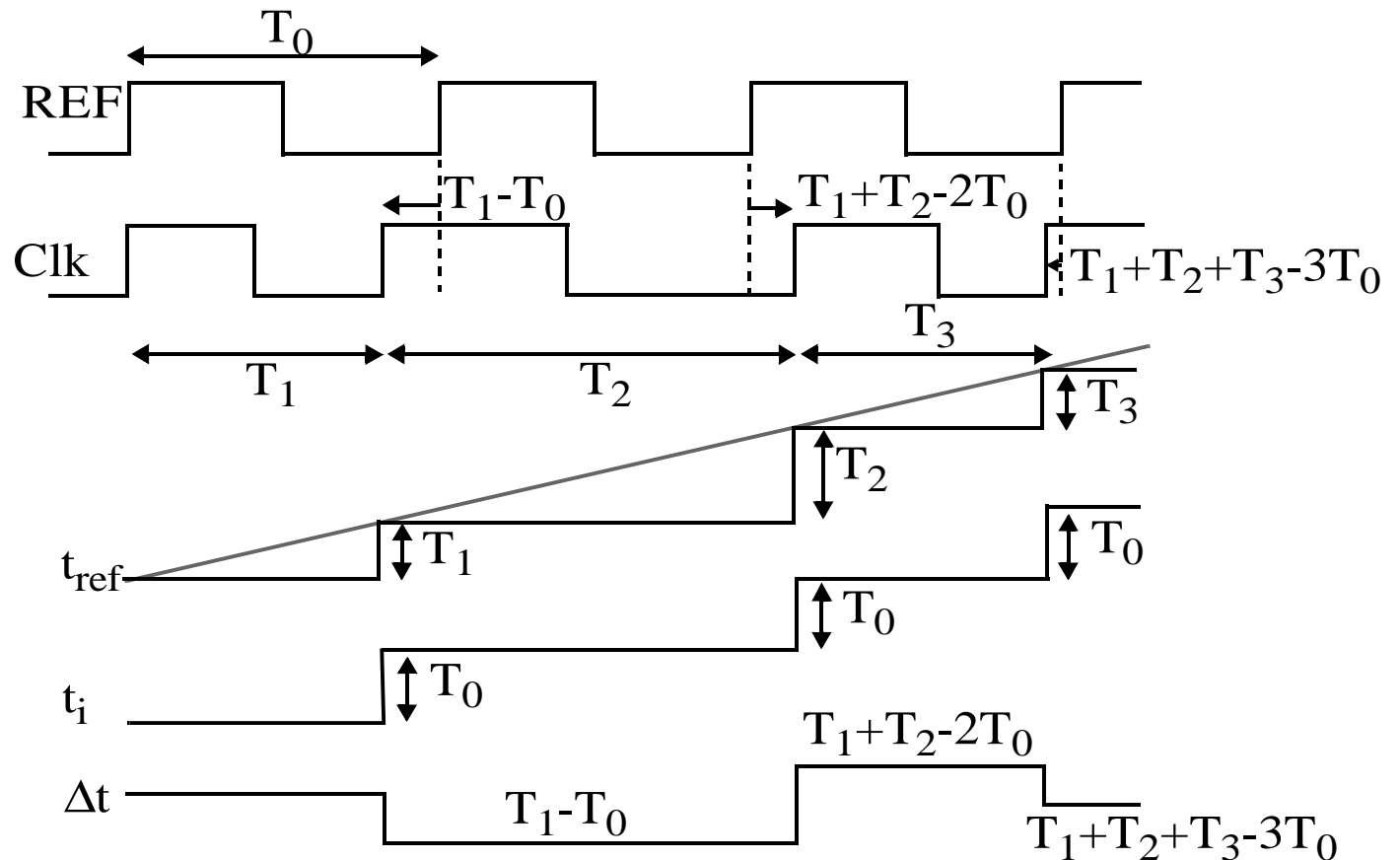
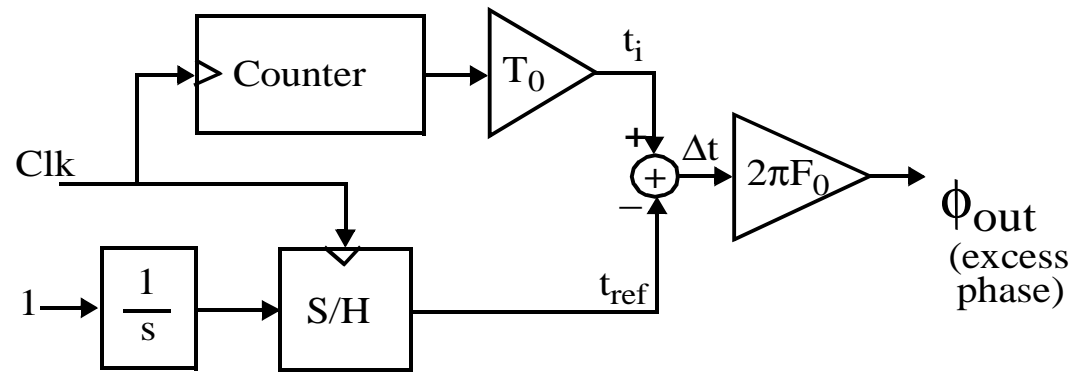

# Behavioral model for an outphasing Tx

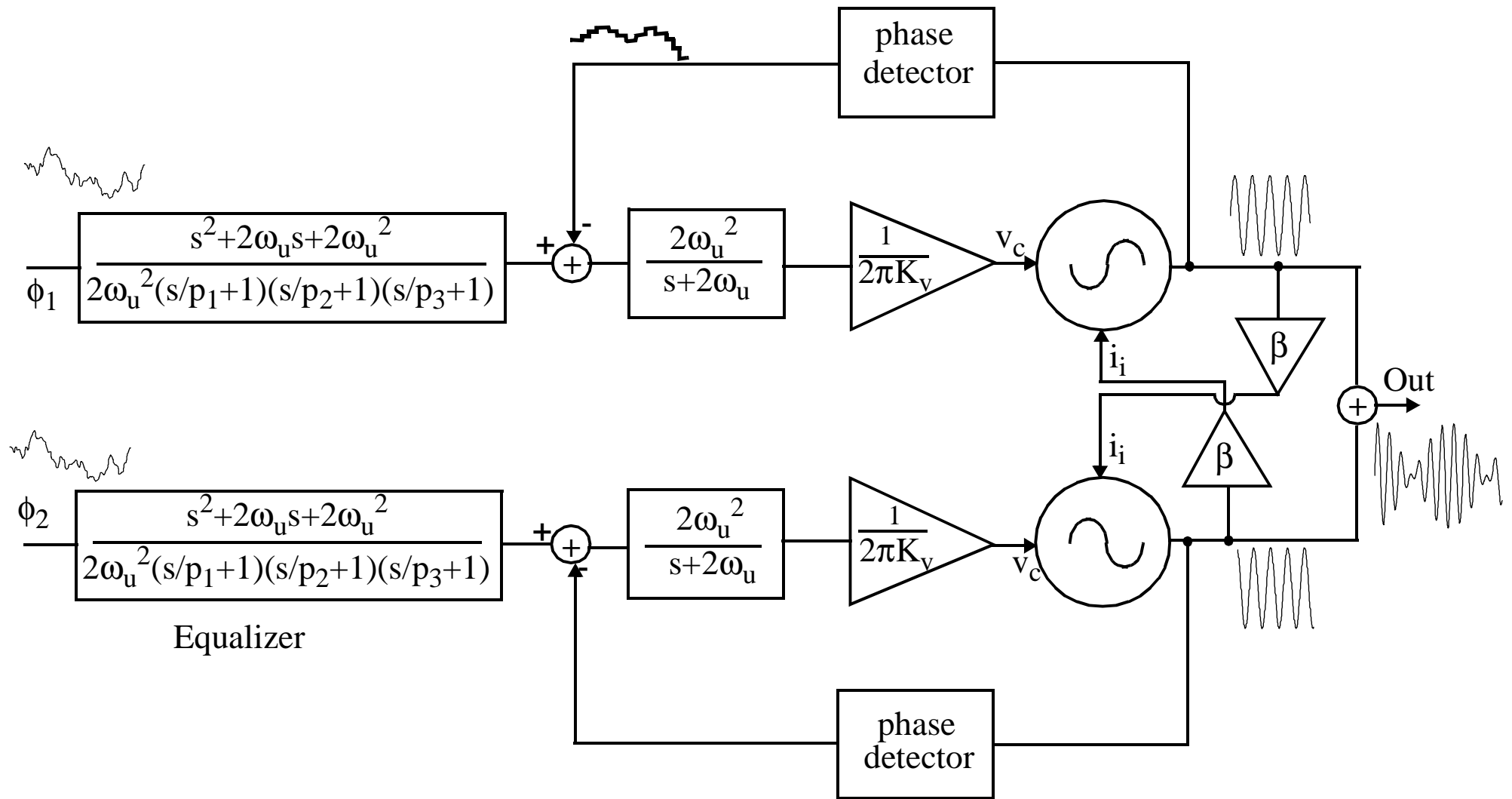

# Linear model

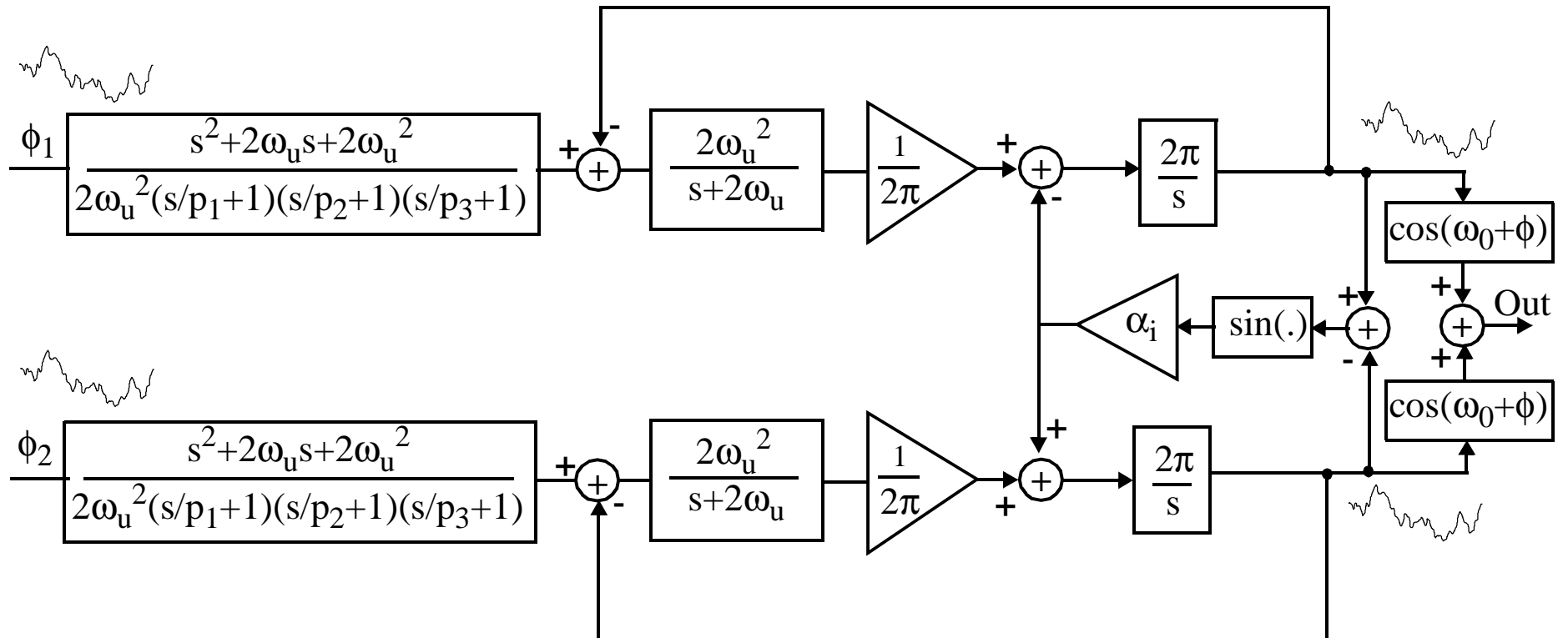

# Simulation Results

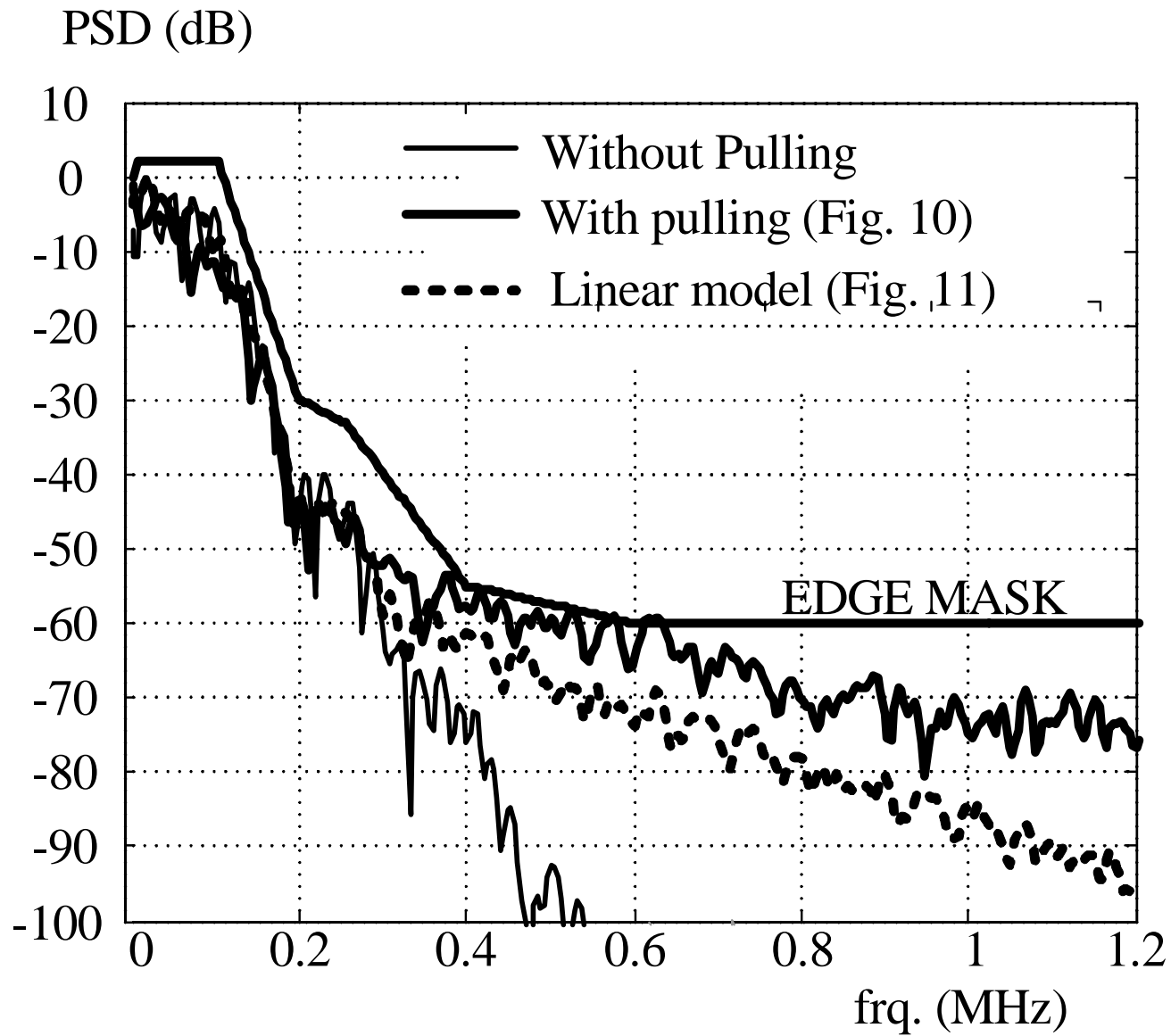

# Conclusion

1. Pulling effect in differential LC oscillator is studied and Adler's equation is derived.
2. A model is introduced to capture the pulling effect in oscillator. This model is extremely simple and can be easily implemented in MATLAB, VERILOG or any high level programming tool.
3. In spite of simpleness, the model gives accurate results which are comparable with measurement results