

Phase Change Memory Modeling Using Verilog-A

Yi-Bo Liao, Yan-Kai Chen, Meng-Hsueh Chiang

Department of Electronic Engineering, National Ilan University

2007/09/21

Outline

- Introduction
 - Phase change memory (PCM)
- Motivation
- Modeling using Verilog-A
- Results

Introduction

- Non-volatile memory (NVM) has been very popular for data storage.
- Phase change memory is promising for the next generation memory device, with the following features:
 - 1) Good scalability
 - 2) Fast read/write (<100ns)
 - 3) Low power operation
 - 4) Good reliability ($>10^6$)

Phase Change Memory (PCM)

- ❑ PCM first presented by S. Ovshinsky in 1968.
- ❑ The material is based on $\text{Ge}_2\text{Sb}_2\text{Te}_5$ (GST).
- ❑ The phase state can be changed by the heat (current pulse).

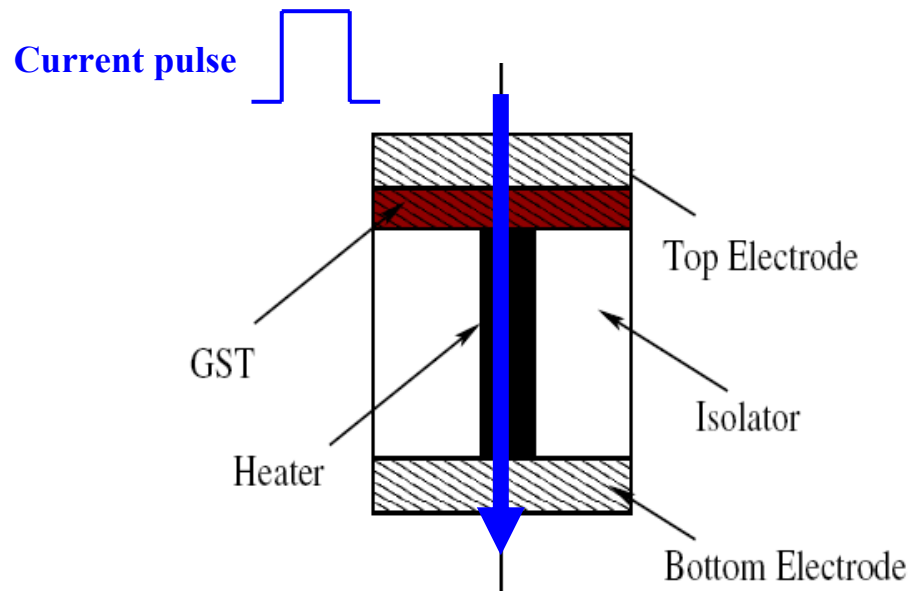

Ref. M. Gh. Mohammad, L. Terkawi, and M. Albasman, "Phase Change Memory Faults," *Proceedings of the 19th International Conference on VLSI Design*, 2006.

Phase Change Memory (PCM)

□ PCM has two static states (phases)

- Crystalline state (Set state) → Low resistance
- Amorphous state (Reset state) → High resistance

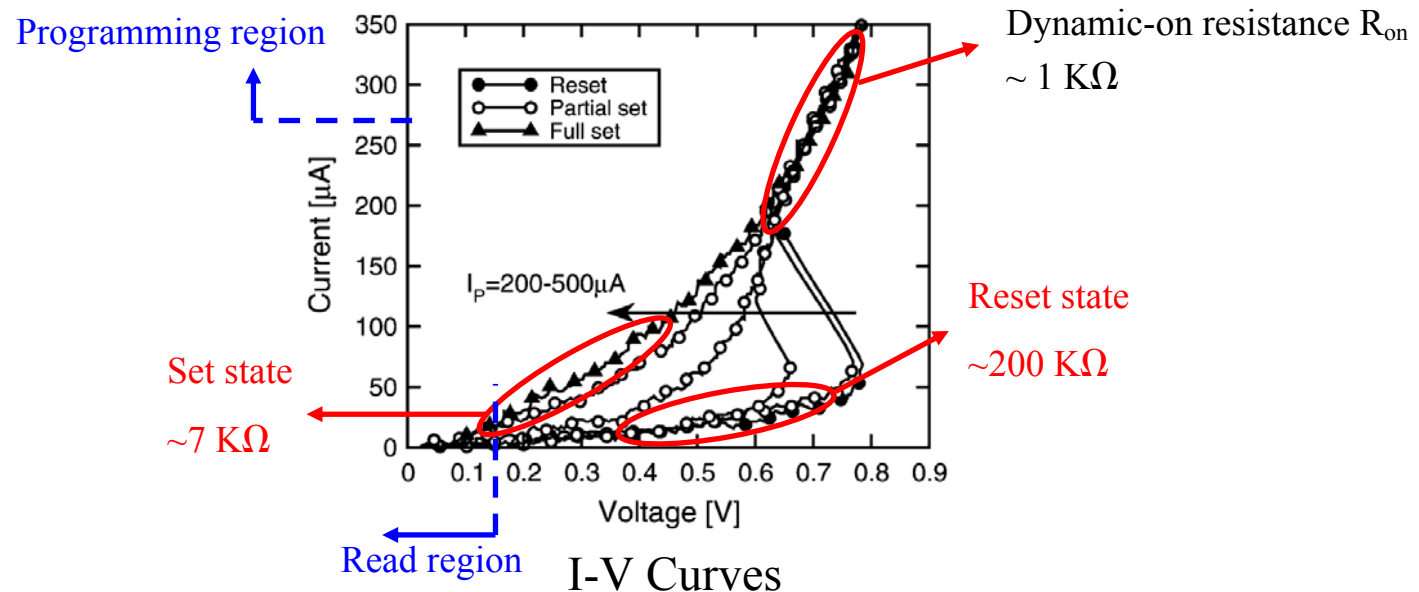

Ref. D.Ielmini, A. L. Lacaita, A. Pirovano, F. Pellizzer, and R. Bez, "Analysis of phase distribution in phase-change nonvolatile memories," *IEEE Electron Device Letters*, Vol. 25, pp. 507-509, July 2004.

Phase Change Memory (PCM)

- PCM state will be changed by current pulse
 - Programming to Set state
 - Programming to Reset state

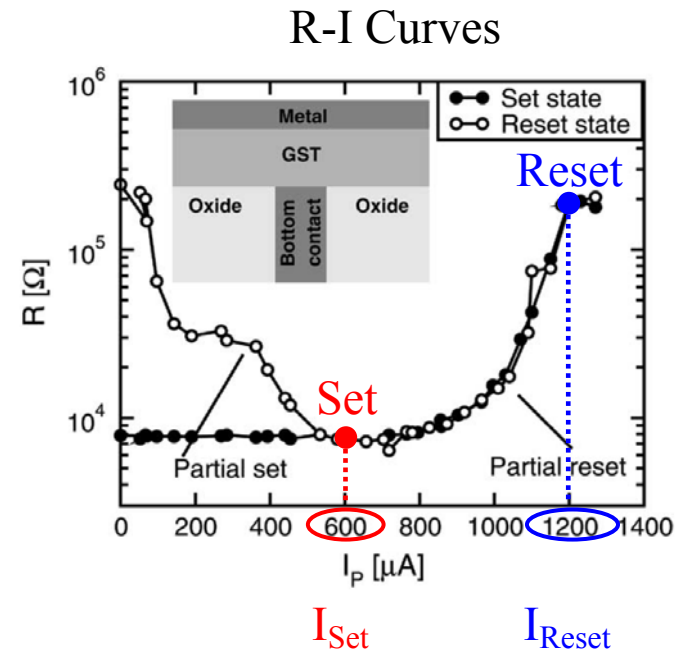
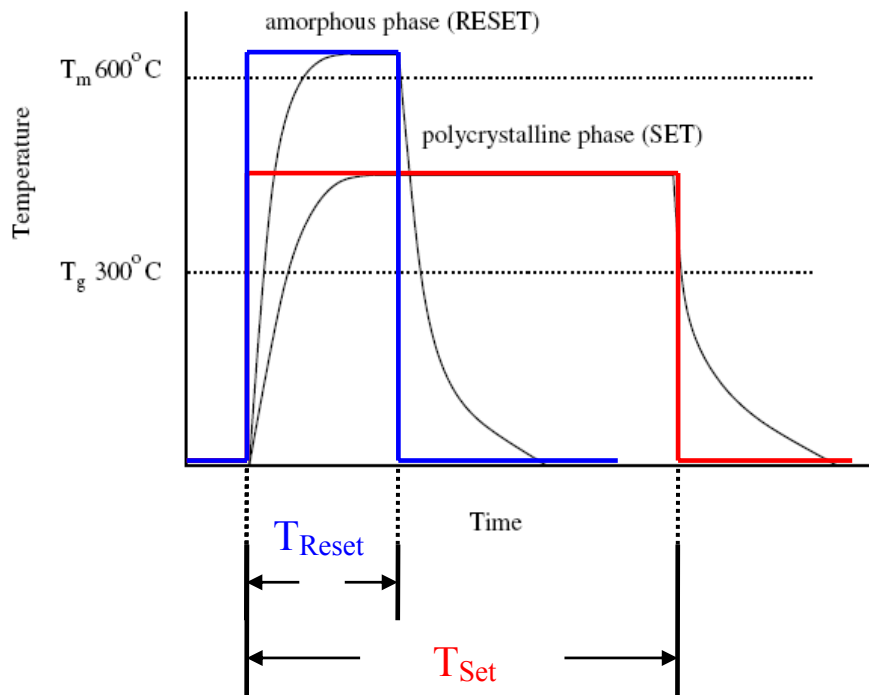

Ref. D.Ielmini, A. L. Lacaita, A. Pirovano, F. Pellizzer, and R. Bez, "Analysis of phase distribution in phase-change nonvolatile memories," *IEEE Electron Device Letters*, Vol. 25, pp. 507-509, July 2004.

Extract Data

- The typical parameters of the proposed PCM model

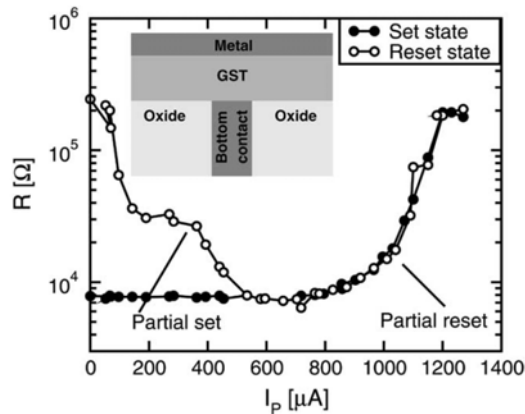
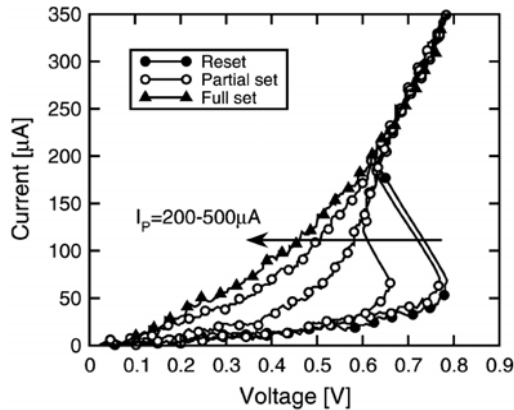

Parameter	Value
Static resistance of Set (R_{Set})	7KΩ
Programming current of Set (I_{Set})	600μA
Programming time of Set (T_{Set})	100ns
Static resistance of Reset (R_{Reset})	200KΩ
Programming current of Reset (I_{Reset})	1200μA
Programming time of Reset (T_{Reset})	50ns
Holding voltage (V_h)	0.45V
Threshold voltage (V_{th})	0.78V
Dynamic-on resistance (R_{on})	1KΩ

Ref. D.Ielmini, A. L. Lacaita, A. Pirovano, F. Pellizzer, and R. Bez, "Analysis of phase distribution in phase-change nonvolatile memories," *IEEE Electron Device Letters*, Vol. 25, pp. 507-509, July 2004.

Motivation

- ❑ PCM has a very nonlinear I-V relation, especially with the snapback characteristic.
- ❑ Convergence problem in SPICE simulator
 - When using too many dependent sources/switches
- ❑ Verilog-A provides a simple tool for behavior modeling and for implementing nonlinear equations.

Modeling

□ The model block chart

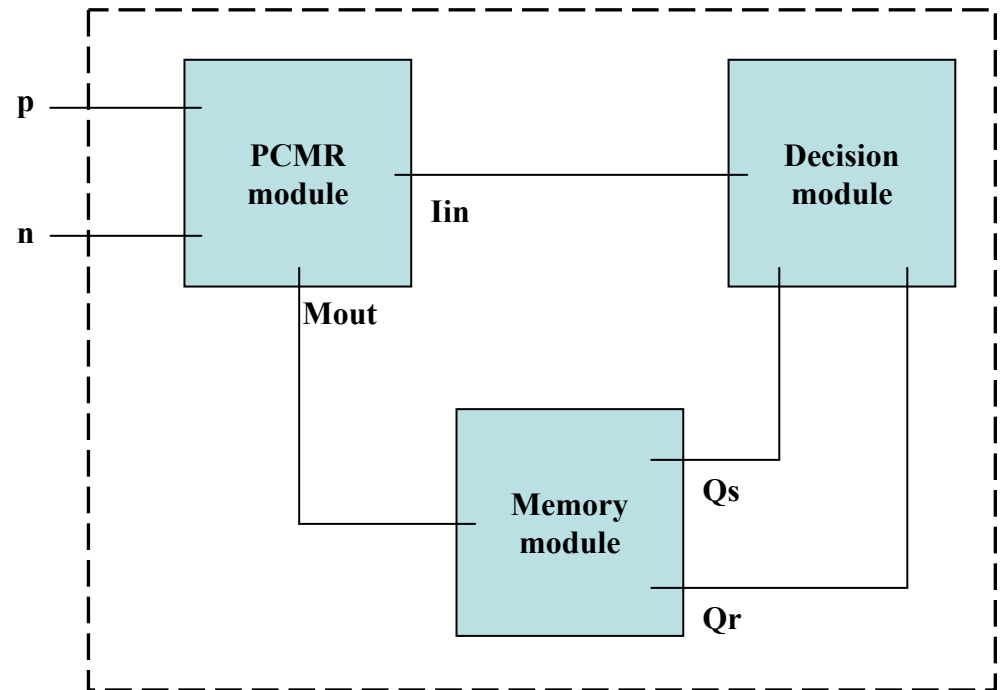
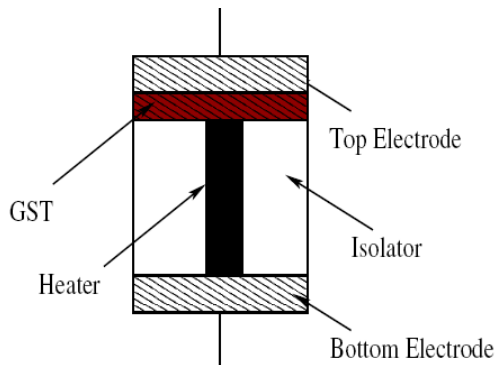

PCMR Module

- To describe the I-V curves of the PCM
- There are two independent I-V curves

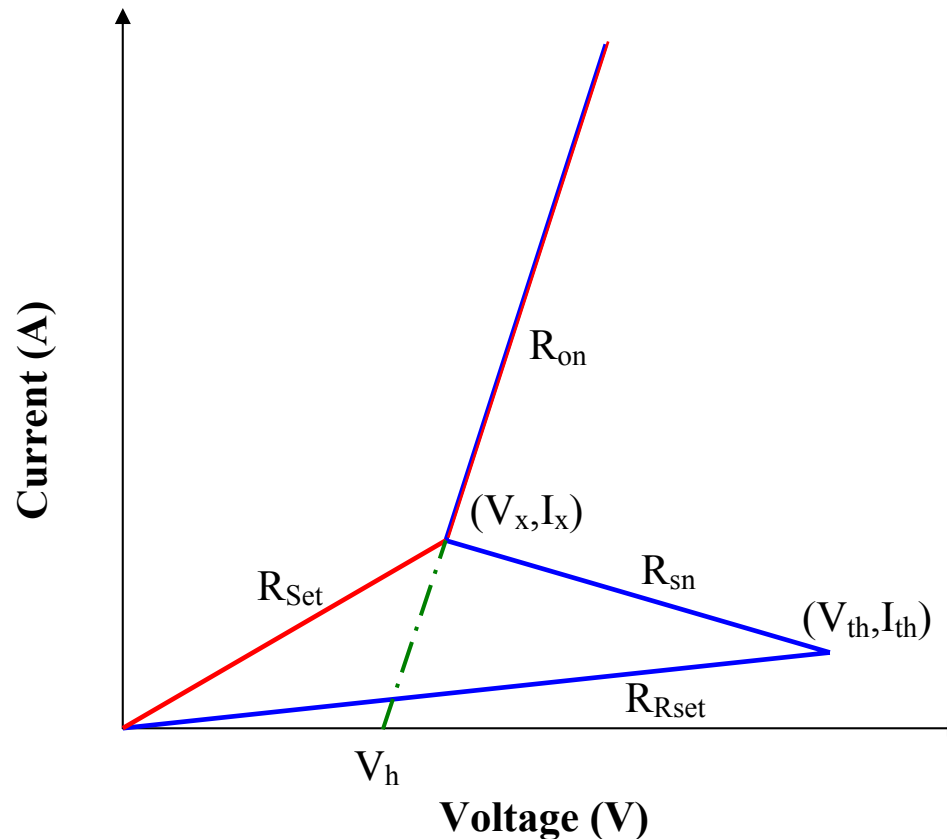

PCMR Module

- The I-V curve of the **Set** state

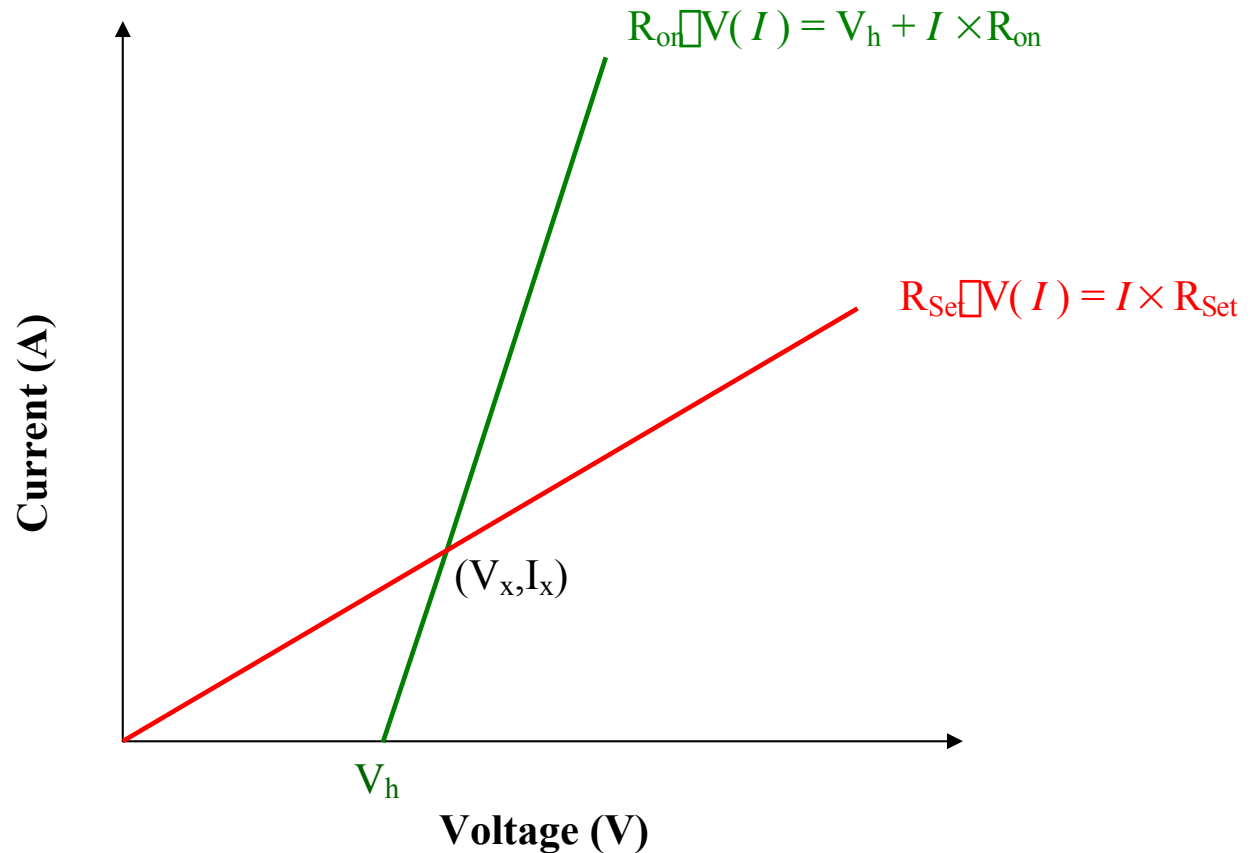

PCMR Module

- The I-V curve of the **Set** state

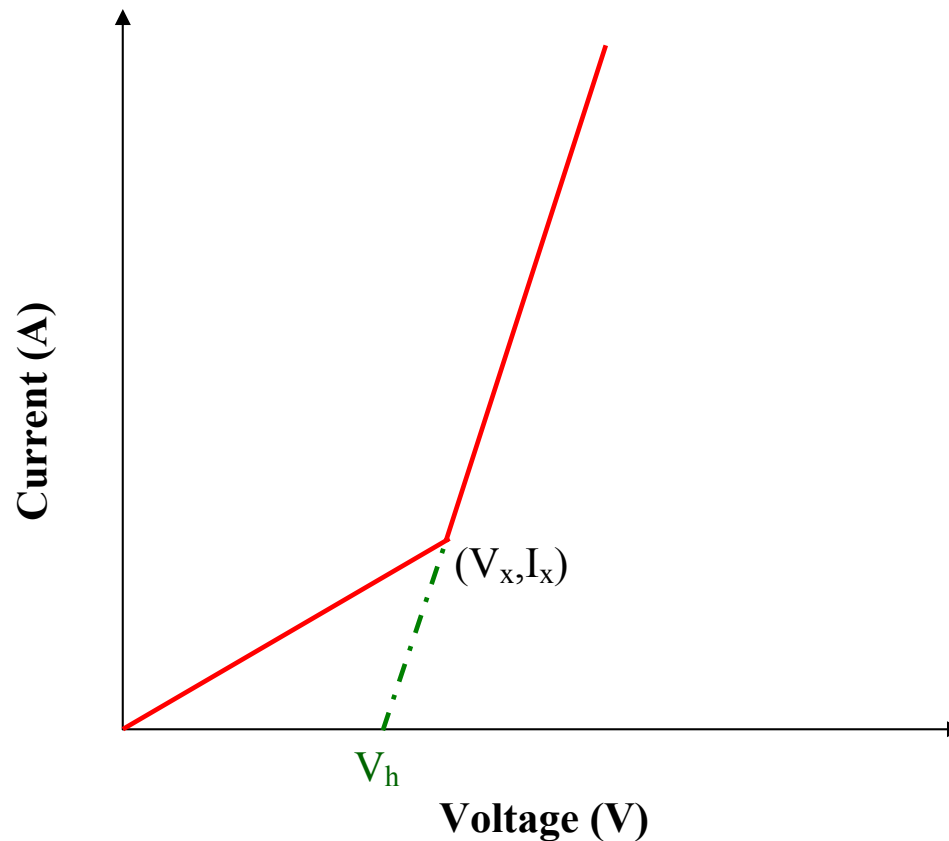

PCMR Module

- The I-V curve of the **Reset** state

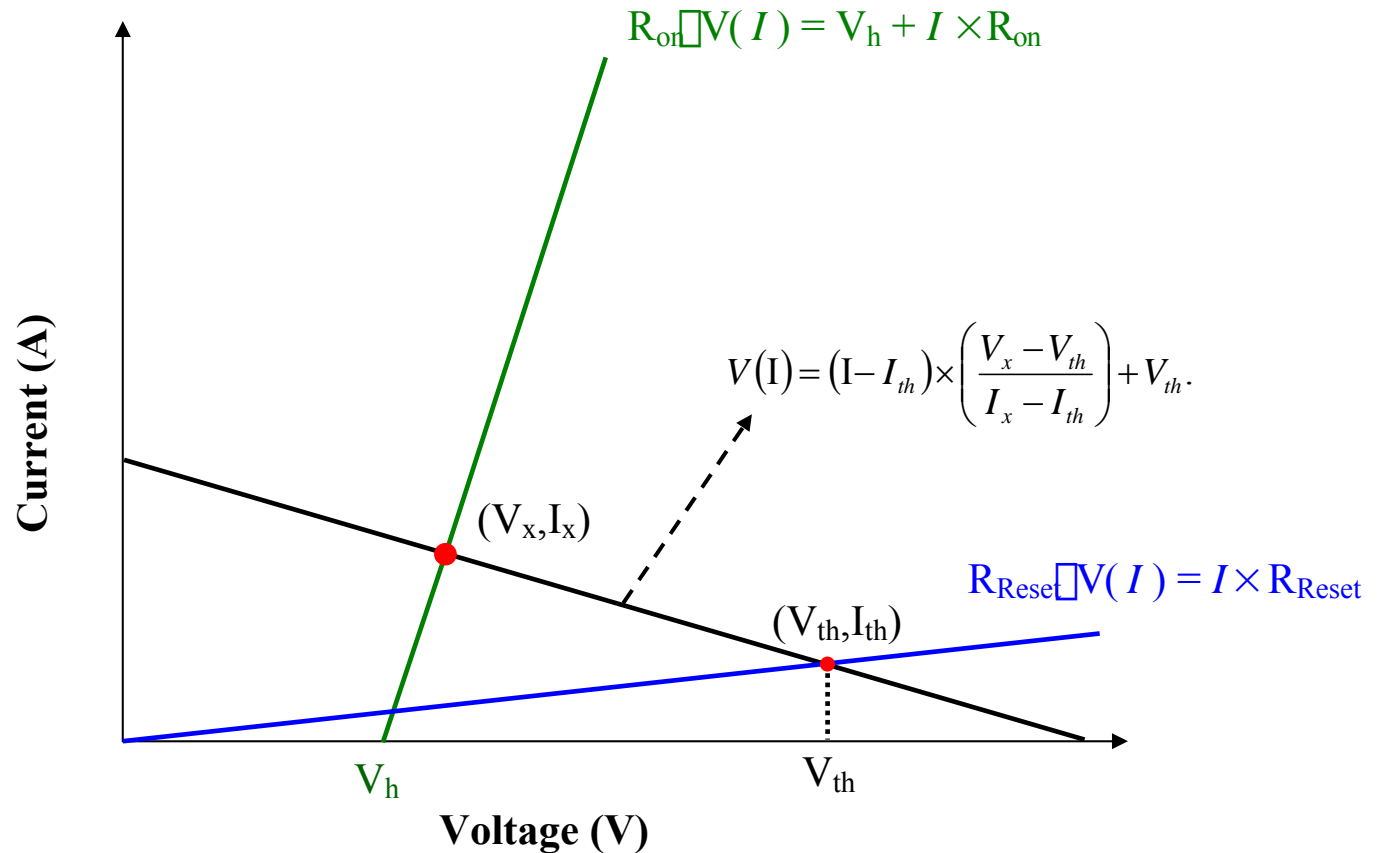

PCMR Module

- The I-V curve of the **Reset** state

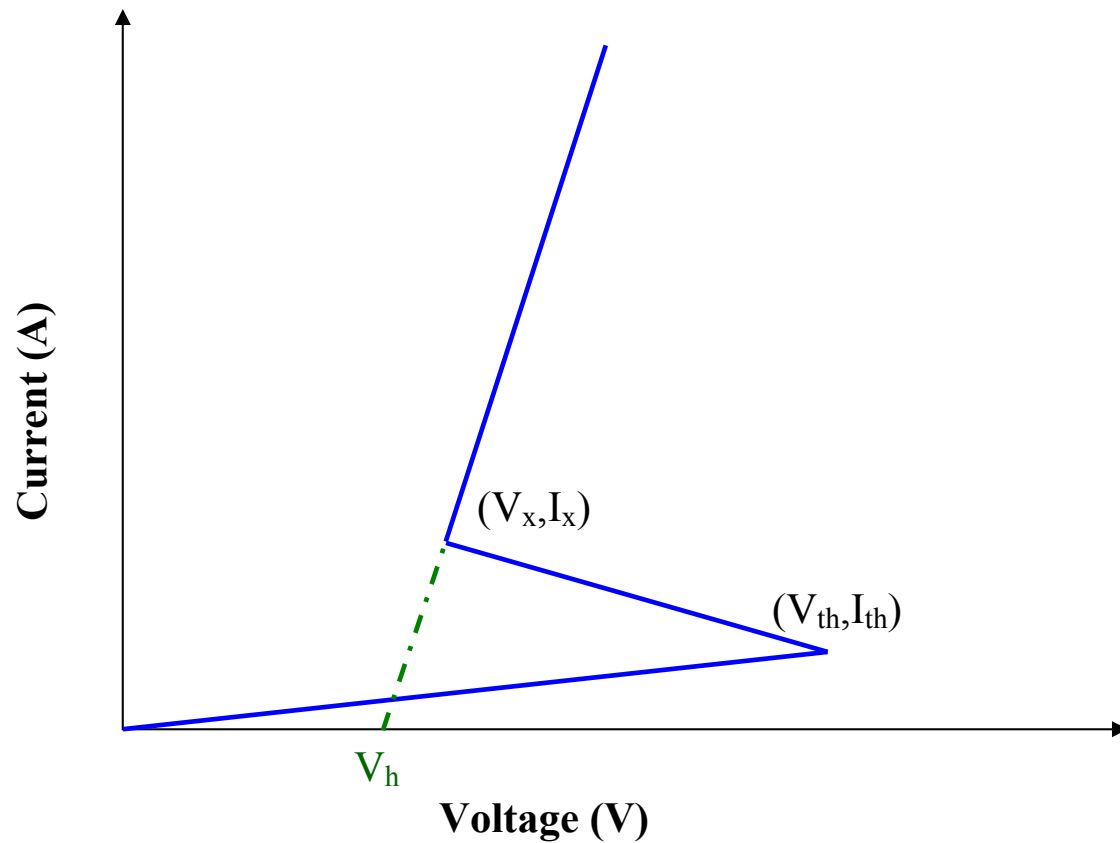

PCMR Module

- Complete I-V curves
- The Set curve or Reset curve were selected by “Memory module”

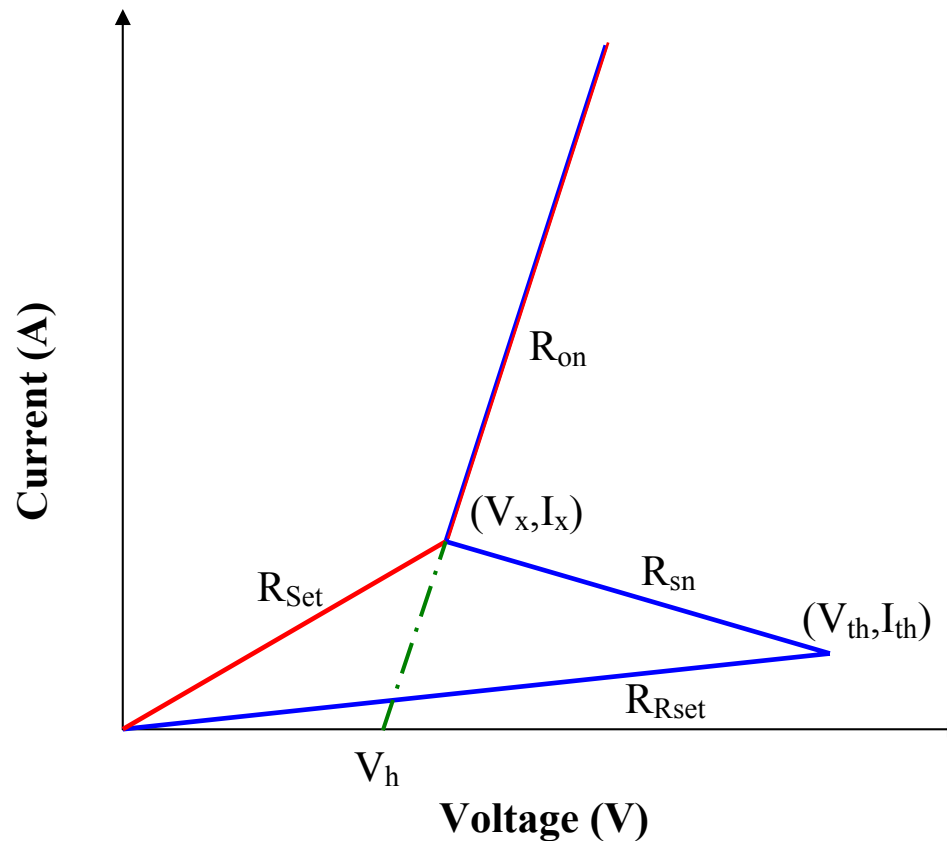

Decision Module

$$I(\text{lin}, \text{gnd}) <+ I(\text{p}, \text{n});$$

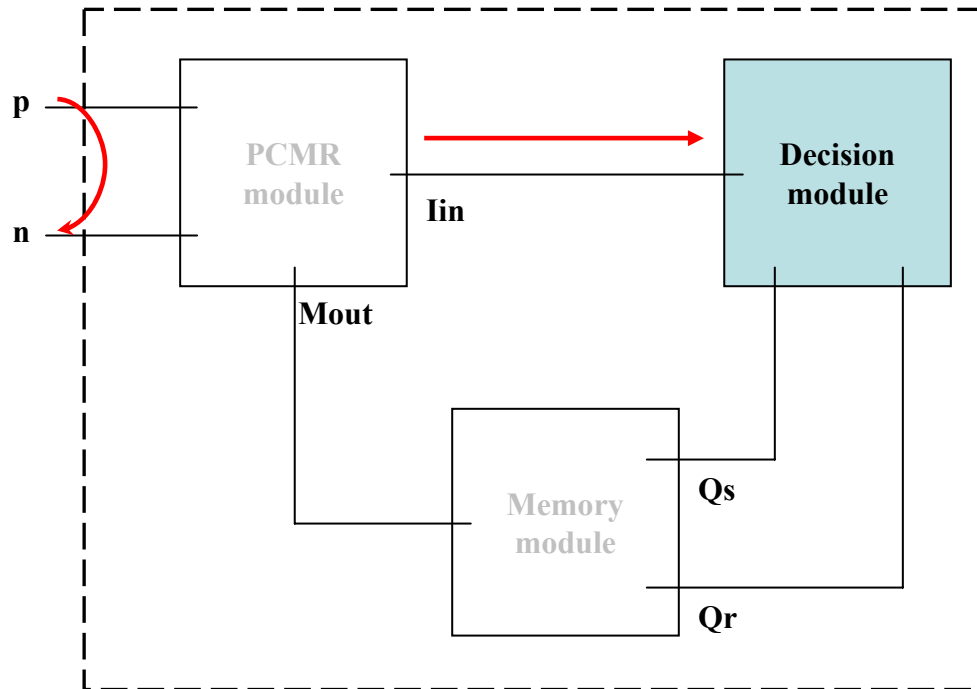

Decision Module

- To determine the current pulse amplitude and width
- Using CCR (Current Control Resistance) to determine the pulse amplitude
- Using RC circuit to determine the pulse width

Decision Module

- The Set and Reset programming conditions are determined respectively

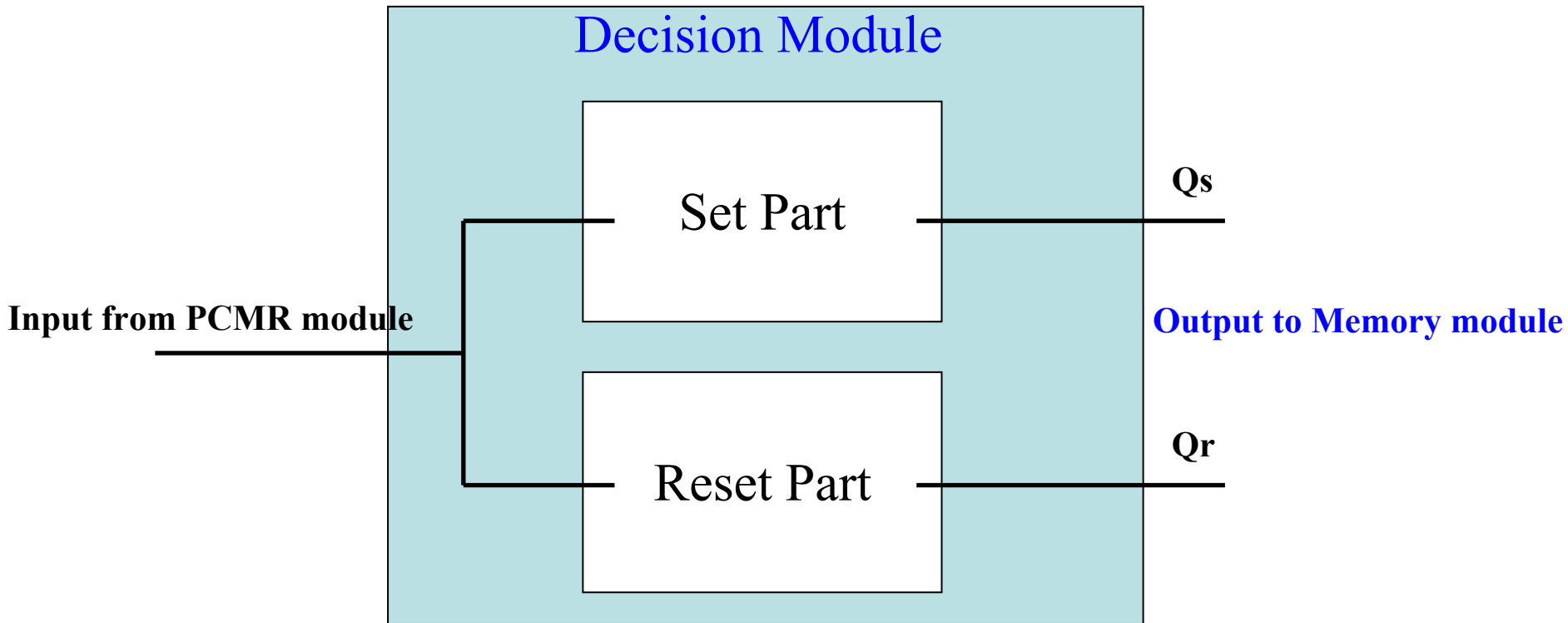

Current Control Resistance (CCR)

- Fermi equation: Smoothing function

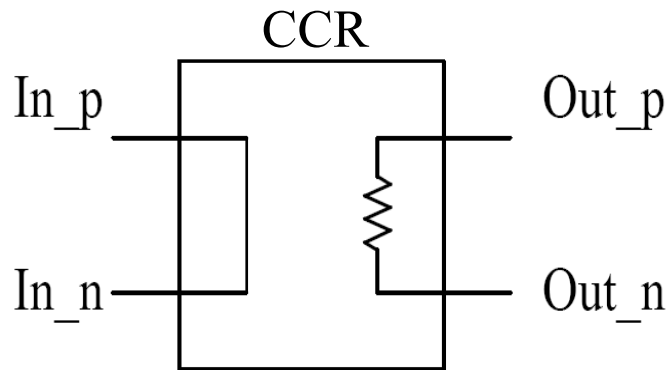

$$R(I) = BS + \frac{AS - BS}{1 + \exp[(I_s - I) \times F]}$$

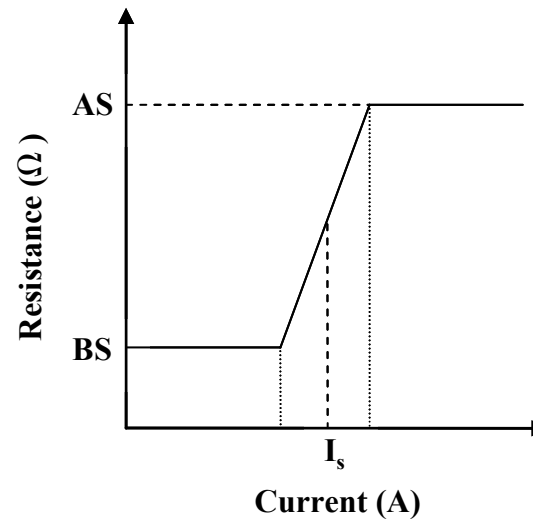

RC Circuit Implement by CCR

RC circuit, implemented with CCR

$$t = R_{rc} C_c \ln \left[\frac{V_{rc}}{V_{rc} - V_{C_c}(t)} \right]$$

Case I. $I_{in} < I_s$ (I_{Set} or I_{Reset})



Case II. $I_{in} > I_s$ (I_{Set} or I_{Reset})

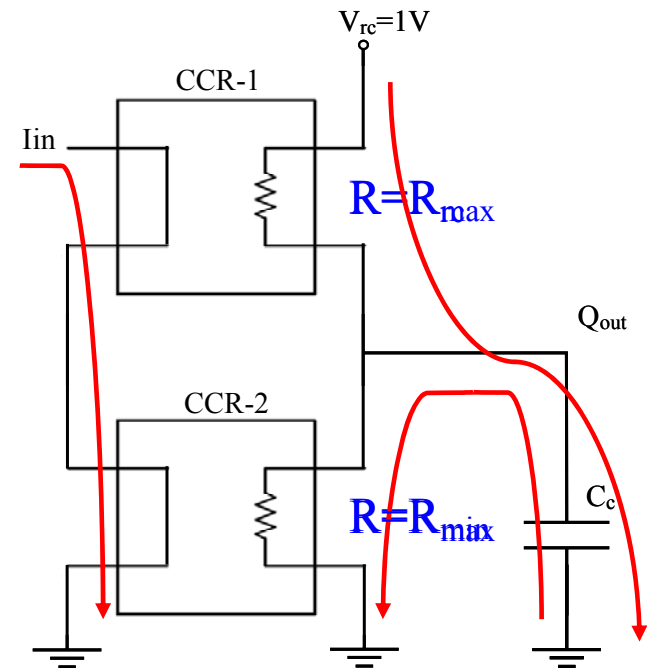
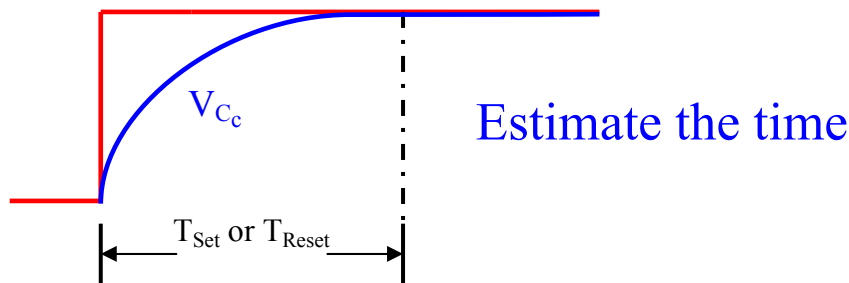

Memory Module

▣ Using VCR and capacitor to record the state

- $Q_r = \text{High voltage}$

Programmed to Reset state

$M_{out} = 3V$ (High stage)

- $Q_s = \text{High voltage}$

Programmed to Set state

$M_{out} = 0V$ (Low stage)

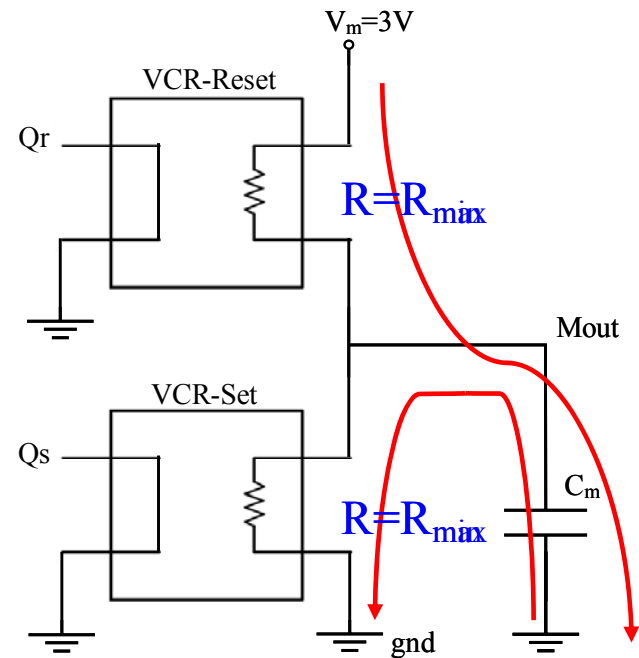

Modeling

□ The model block chart

- Q_r =High stage
- ~~M_{out}~~ =High stage
- ~~Reset curve will be selected~~

- Q_s =High stage
- ~~M_{out}~~ =Low stage
- ~~Set curve will be selected~~

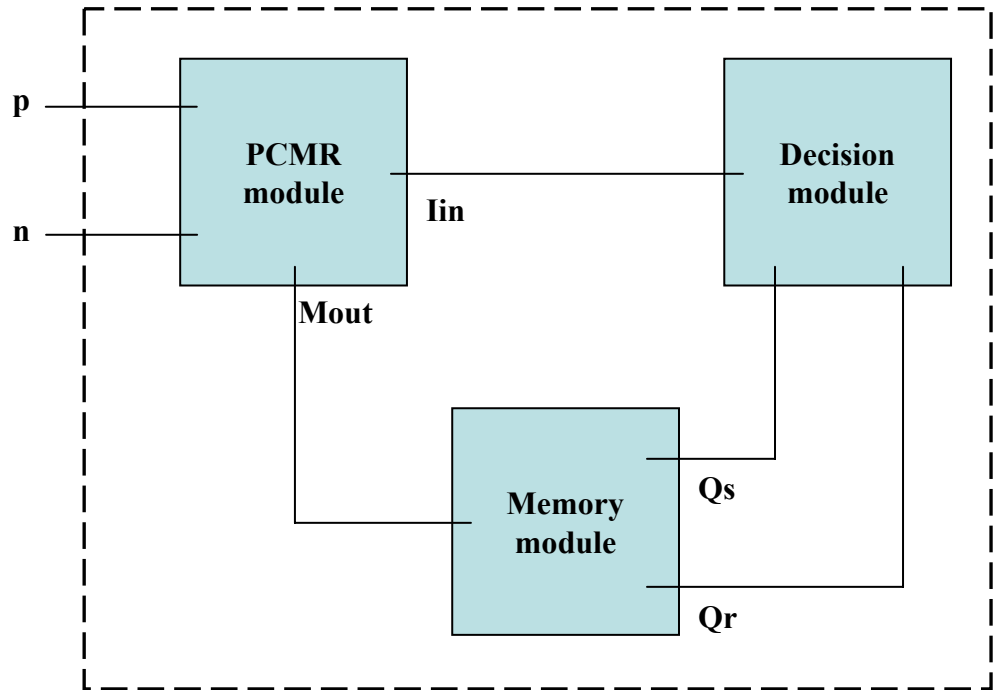

Simulation Results

- Verilog-A model evaluation using HSPICE
 - DC sweep analysis
 - Transient analysis

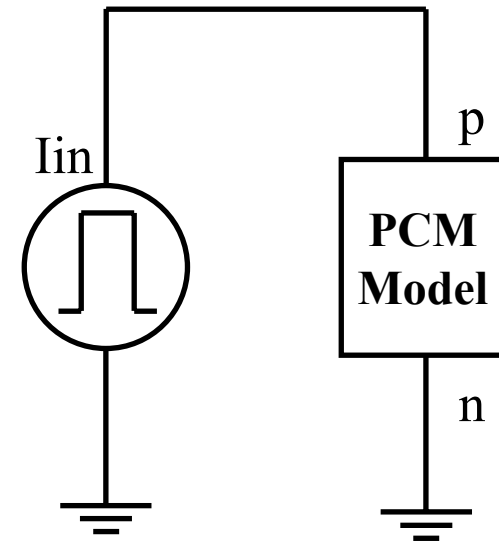
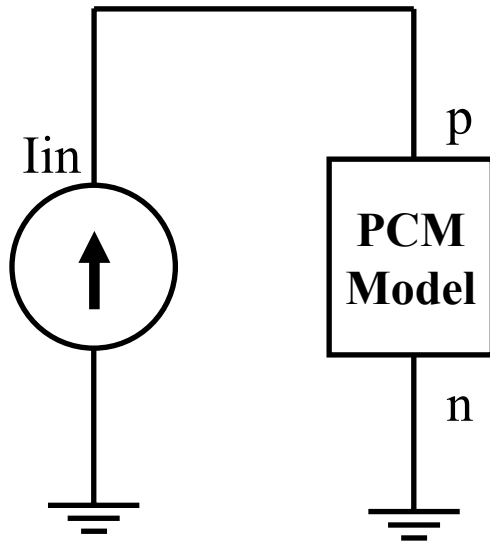

Simulation Results

□ DC sweep analysis (I-V curves)

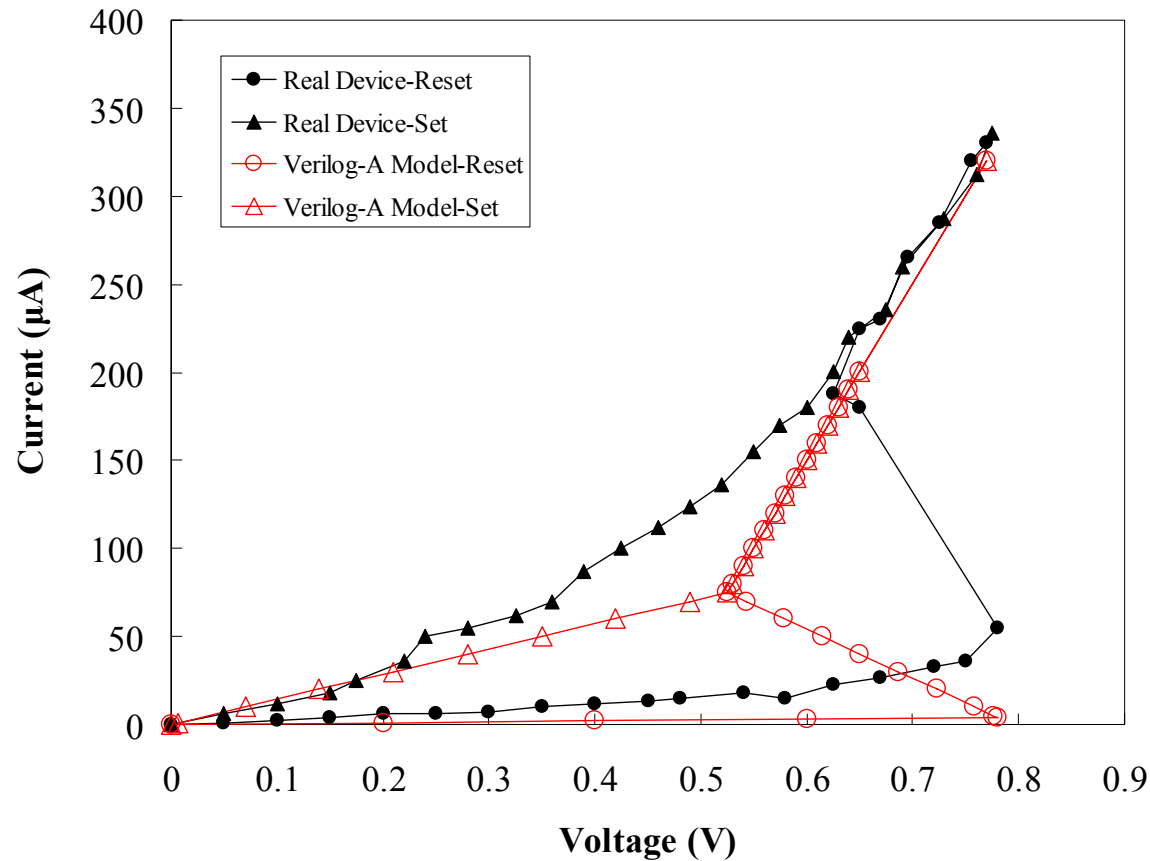

Simulation Results

- Transient analysis
- Input the current pulse to change the PCM resistance

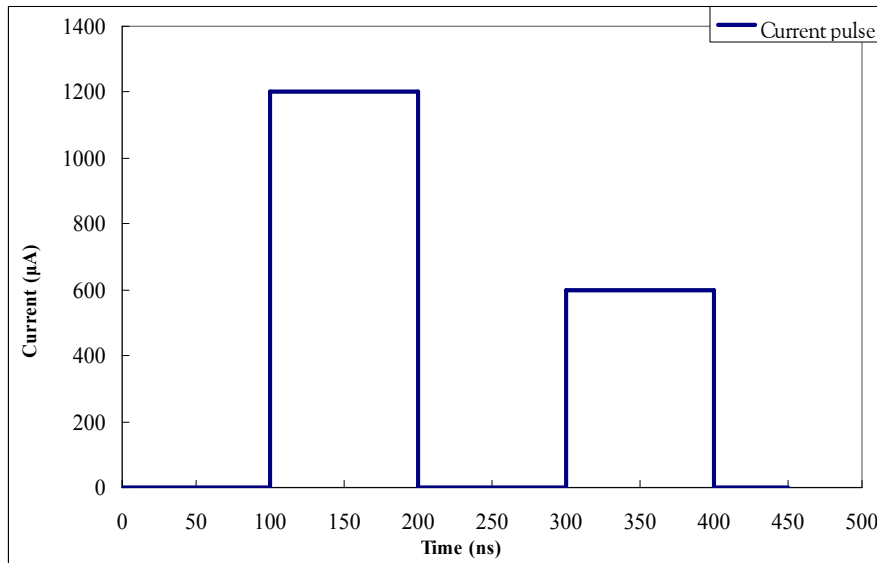

Input current pulse

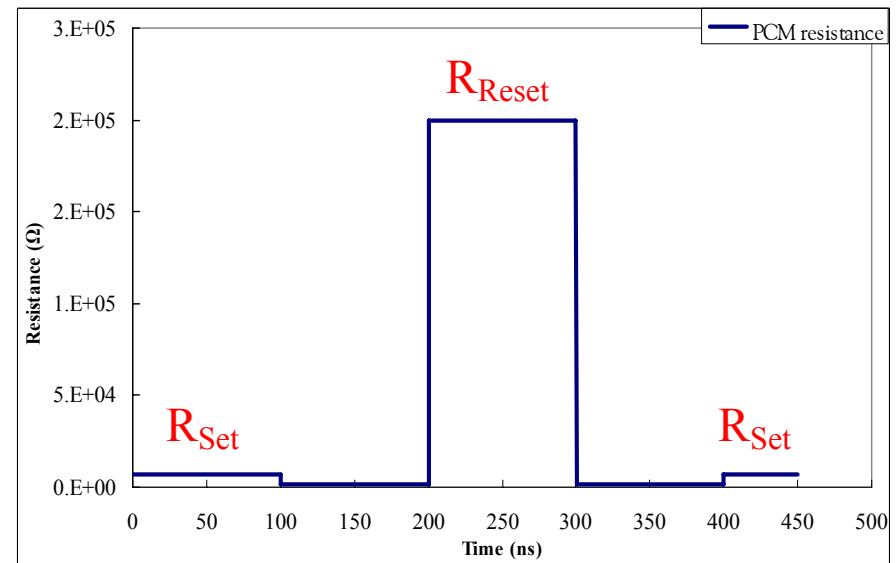

PCM resistance

Simulation Results

□ R-I curves

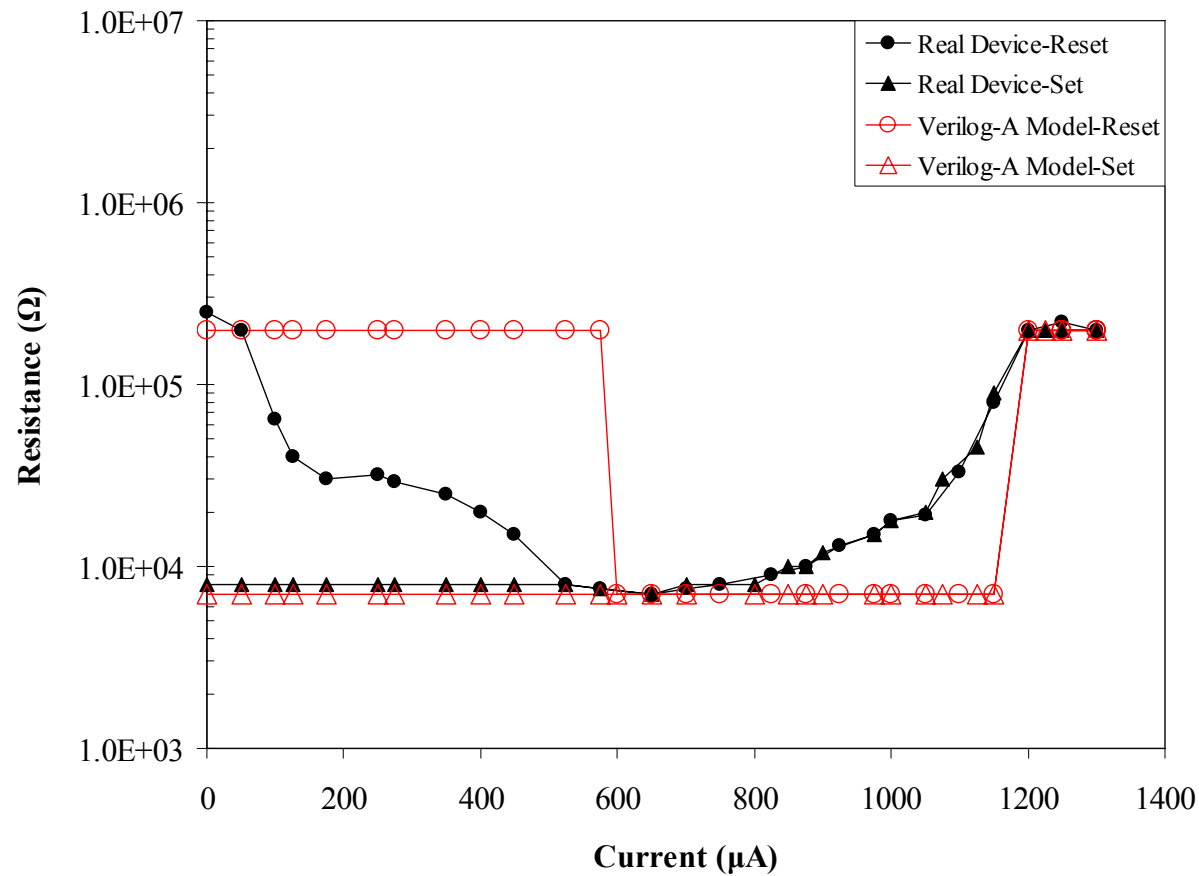

Conclusions

- We have presented a compact PCM model using Verilog-A.
- The model is predictive, yet simple to use.
- The model can be implemented in any circuit simulators with the Verilog-A option.
- PCM modeling with Verilog-A is flexible and has good convergence based on our simulation.

Thanks For Your Attendance

