

# Prediction of Harmonic Distortion in ADCs using Dynamic Integral Non-Linearity Model

presented by:

Hamza Fraz

# Introduction to Problem

- Analog-to-Digital Converters (ADCs) impair a signal's fidelity
- Two kinds of impairments
  - Noise
    - almost always independent of the input signal
    - places a limit on signal integrity
  - Distortion
    - almost always a function of input signal
    - can be predicted / corrected *if* dynamics causing the distortion are known
- Goal: **Predict / Correct Distortion!**

# How distortion is measured?

- Frequency Domain
  - Spurious Free Dynamic Range (dBc/dBFS)
  - Total Harmonic Distortion (dBc)
- Time domain
  - Differential Non-linearity (DNL)
  - Integral Non-linearity (INL)

# 12-bit, 250 MSPS ADC (Time Domain)

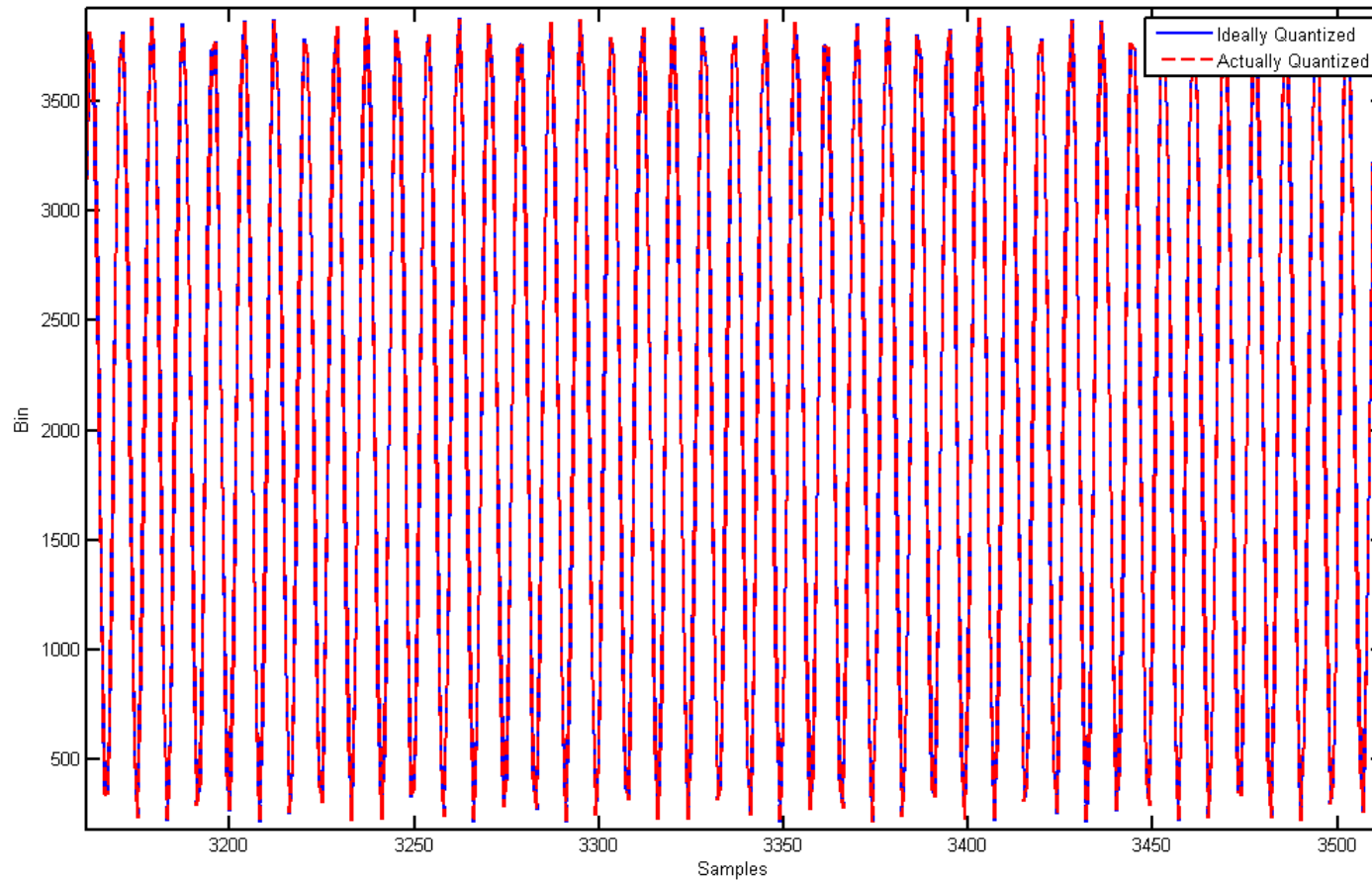

# Ideal 12-bit, 250 MSPS ADC (Spectrum)

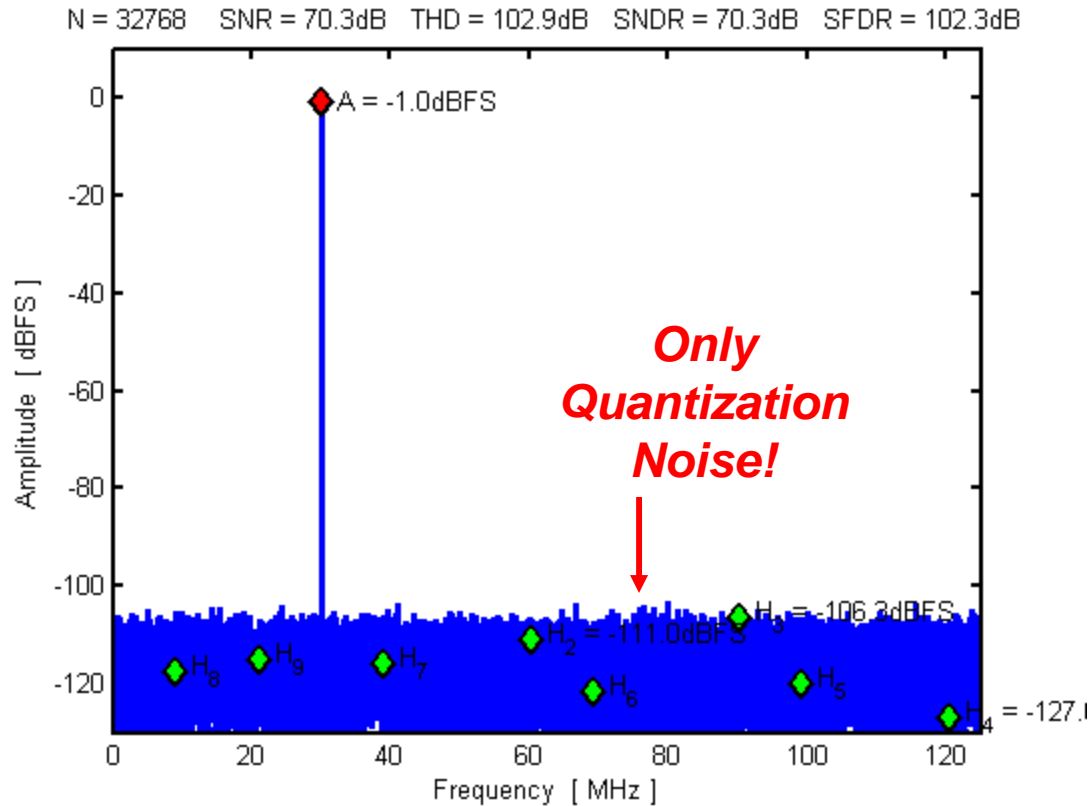

# Actual 12-bit, 250 MSPS ADC (Spectrum)

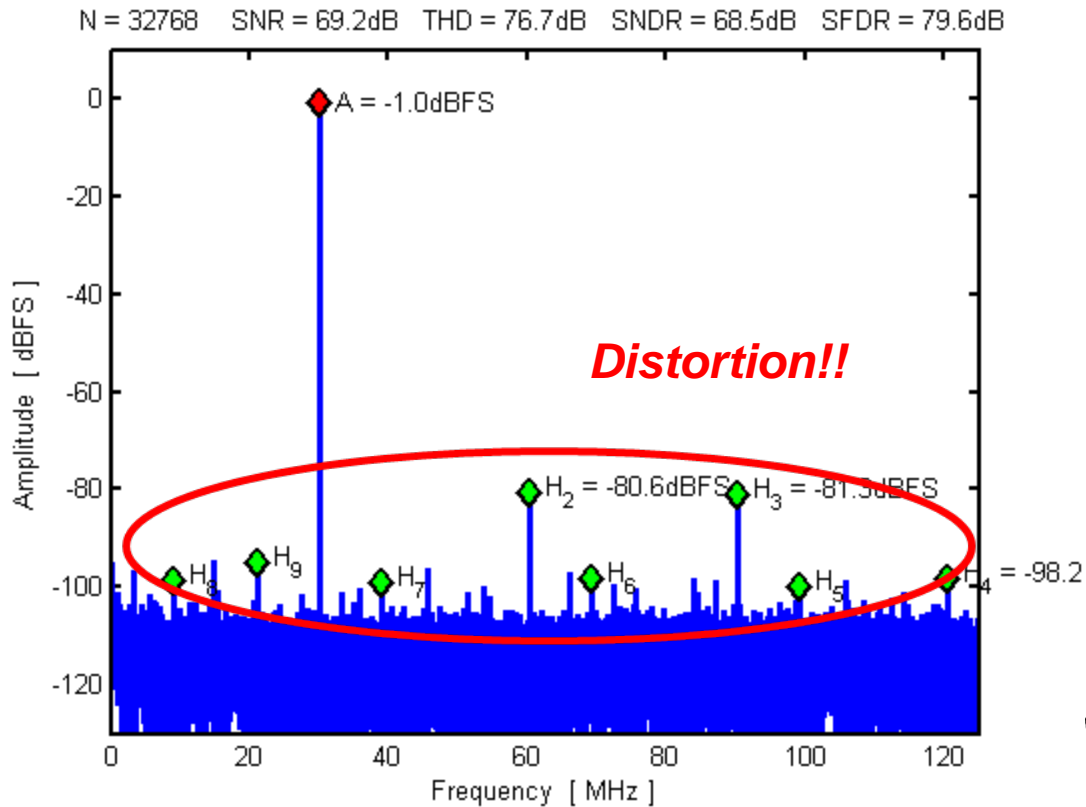

# INL/DNL Definition

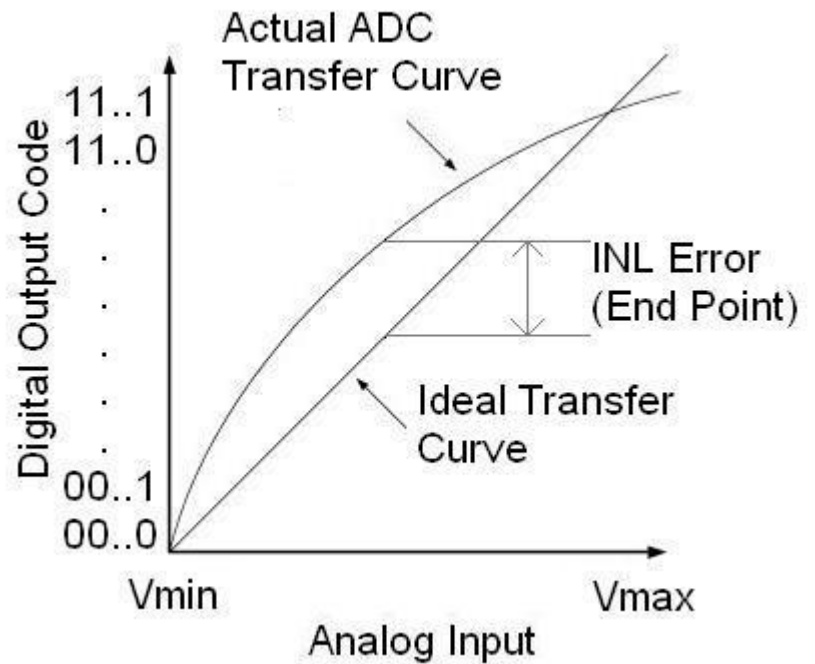
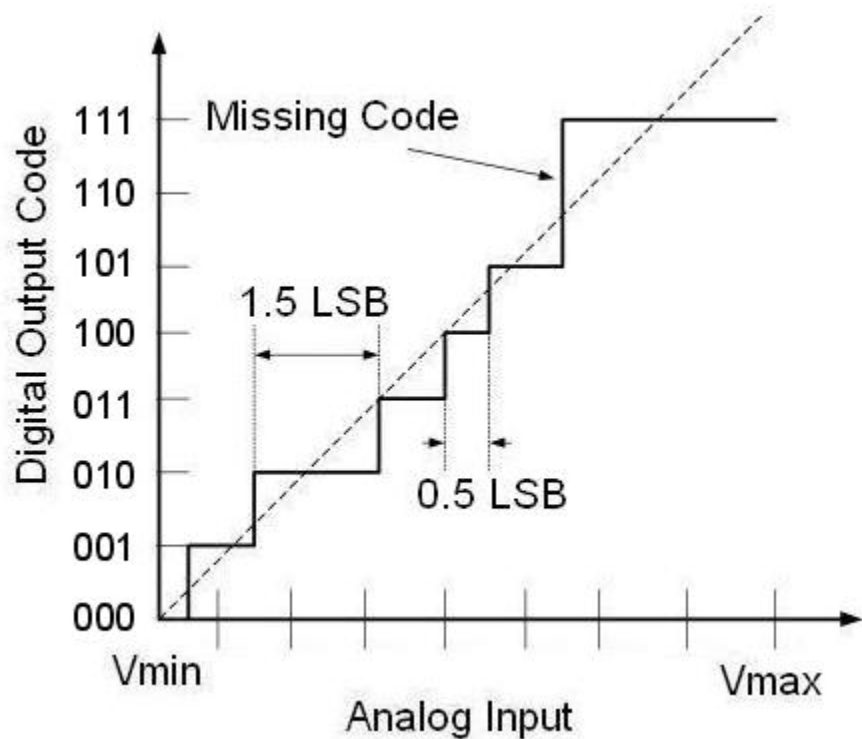

# 12-bit, 250 MSPS ADC (Time Domain, Unwrapped)

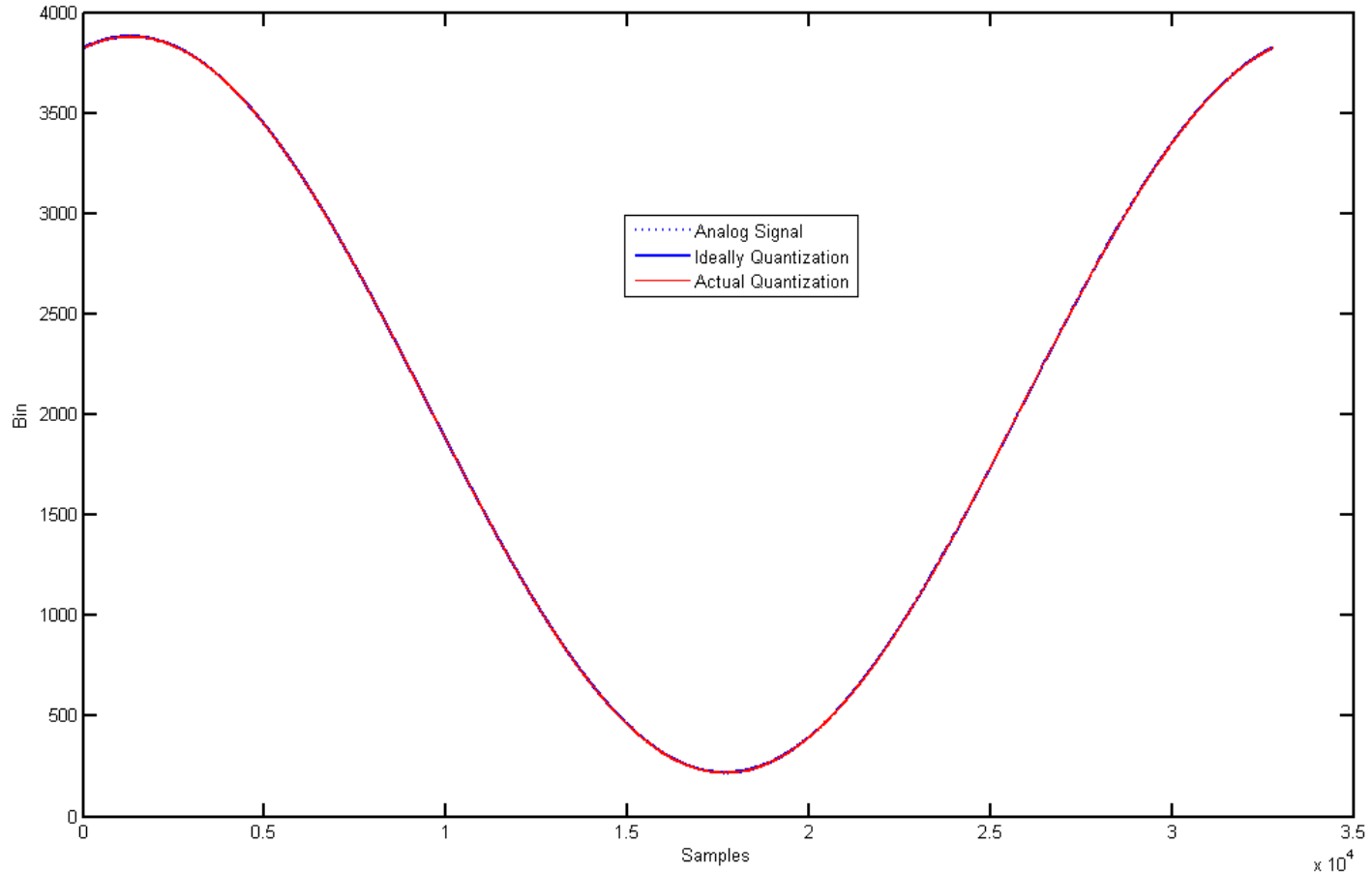

# 12-bit, 250 MSPS ADC (Time Domain , Unwrapped)

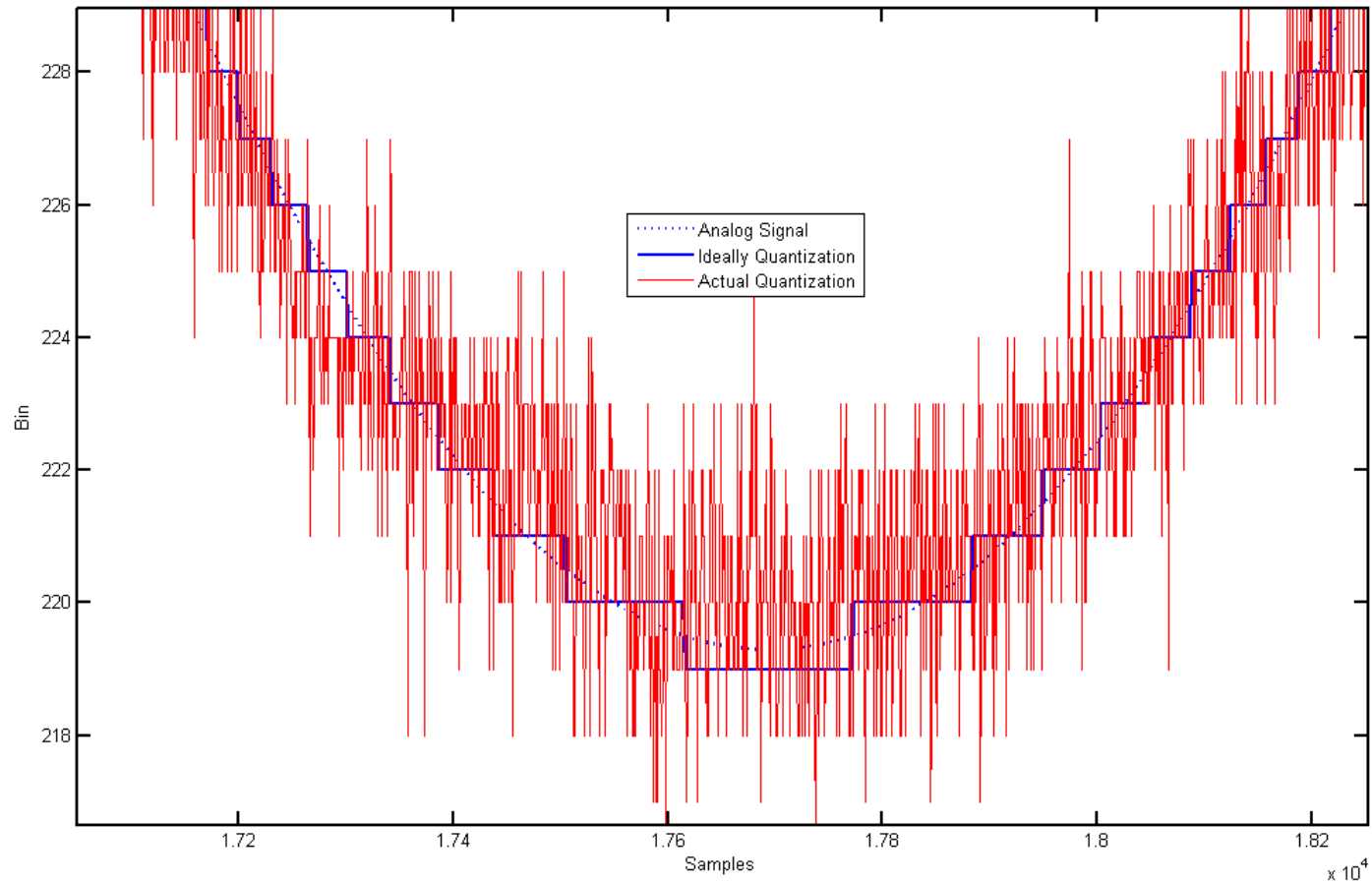

# 12-bit, 250 MSPS ADC (Time Domain , Unwrapped, Mean)

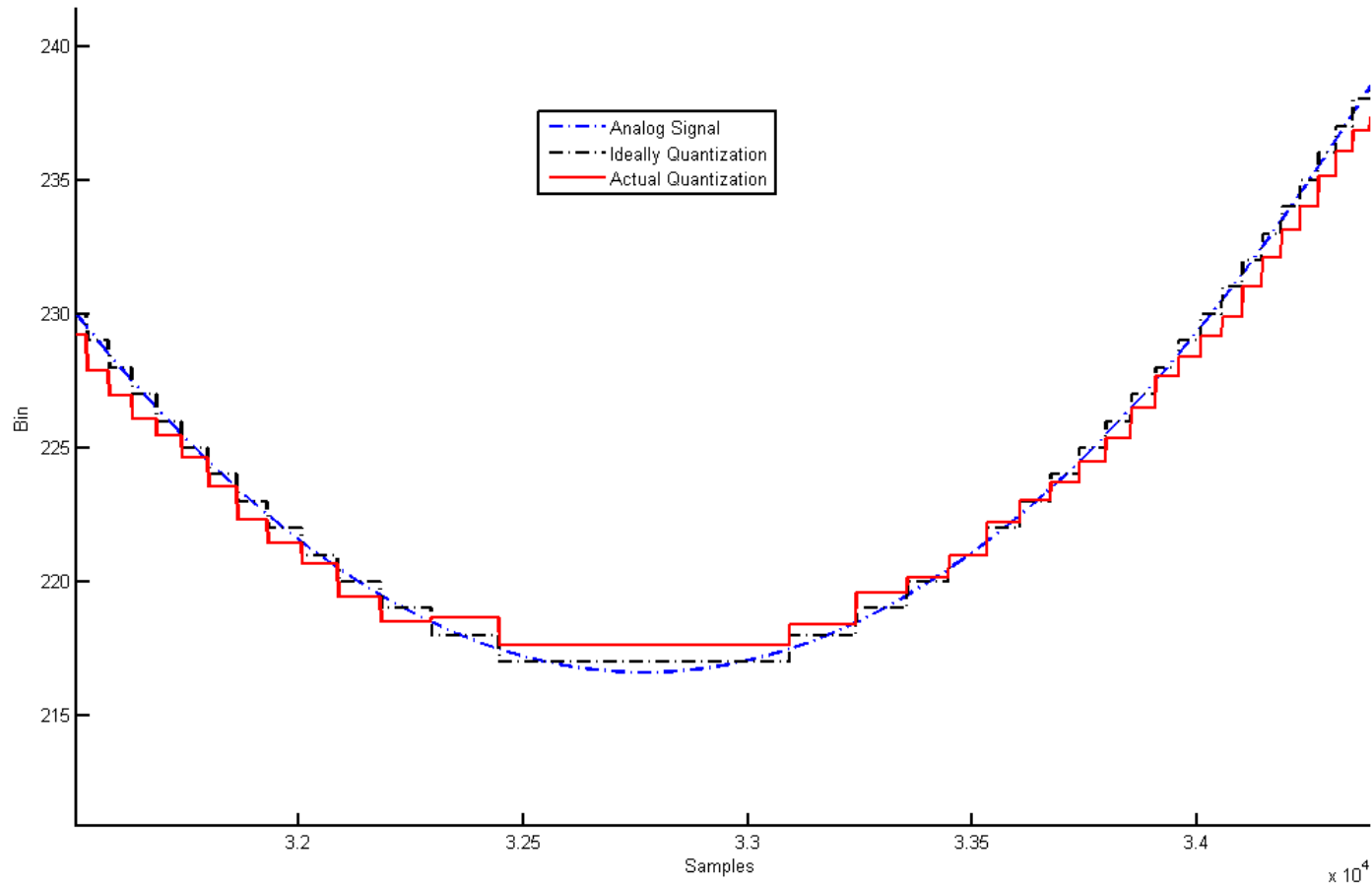

# ADC Transfer Function: INL Curve

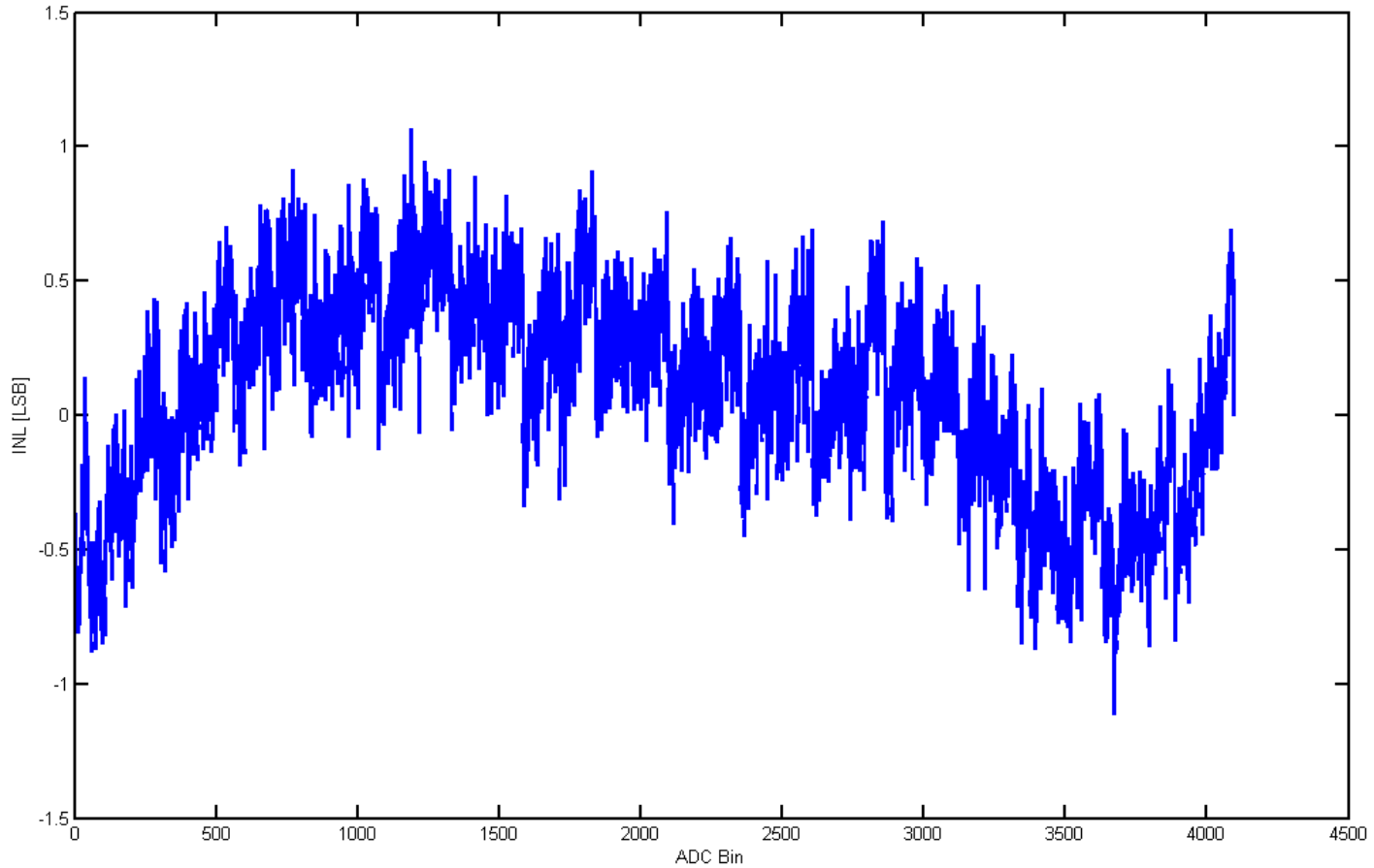

# This Work

- is about modeling the INL curve, which in turns models the distortion observed in a 12-bit, 250 MSPS ADC from Texas Instruments
- presents an approach that models the INL curve using 'sum of sines' (similar to a Fourier Series)
  - compares the results to earlier presented works in which the INL curve has been modeled with piece-wise linear functions

# Mathematical Foundation

The INL curve can be seen as the superposition of a smoothly varying function, termed as Low Code Frequency (LCF) INL and a rapidly changing function, termed as High Code Frequency (HCF) INL. For code **k** in a **B**-bit ADC, the INL transfer function can be written as

$$\text{INL}[k] = {}^{\text{HCF}} \text{INL}[k] + {}^{\text{LCF}} \text{INL}[k] + {}^{\text{Noise}} \text{INL}[k]$$

# Mathematical Foundation [cont.]

The errors in the ADC are frequency dependent i.e. ADC errors have a memory effect. Therefore,

$$\text{INL}[k, w] = {}^{\text{HCF}} \text{INL}[k] + {}^{\text{LCF}} \text{INL}[k, w] + {}^{\text{Noise}} \text{INL}[k, w]$$

For simplicity, HCF INL is assumed to be static.

# Mathematical Foundation [cont.]

The LCF component of INL is modeled by a polynomial non-linearity with frequency dependent coefficients

$${}^{\text{LCF}}\text{INL}[k, w] = h_0(w) + h_1(w)k + h_2(w)k^2 + \dots + h_L(w)k^L$$

The HCF component of INL is modeled by a finite summation of sine waves with independent parameters

$${}^{\text{HCF}}\text{INL}[k] = a_1 \sin(b_1 x + c_1) + \dots + a_8 \sin(b_8 x + c_8)$$

# LCF INL Model Illustration

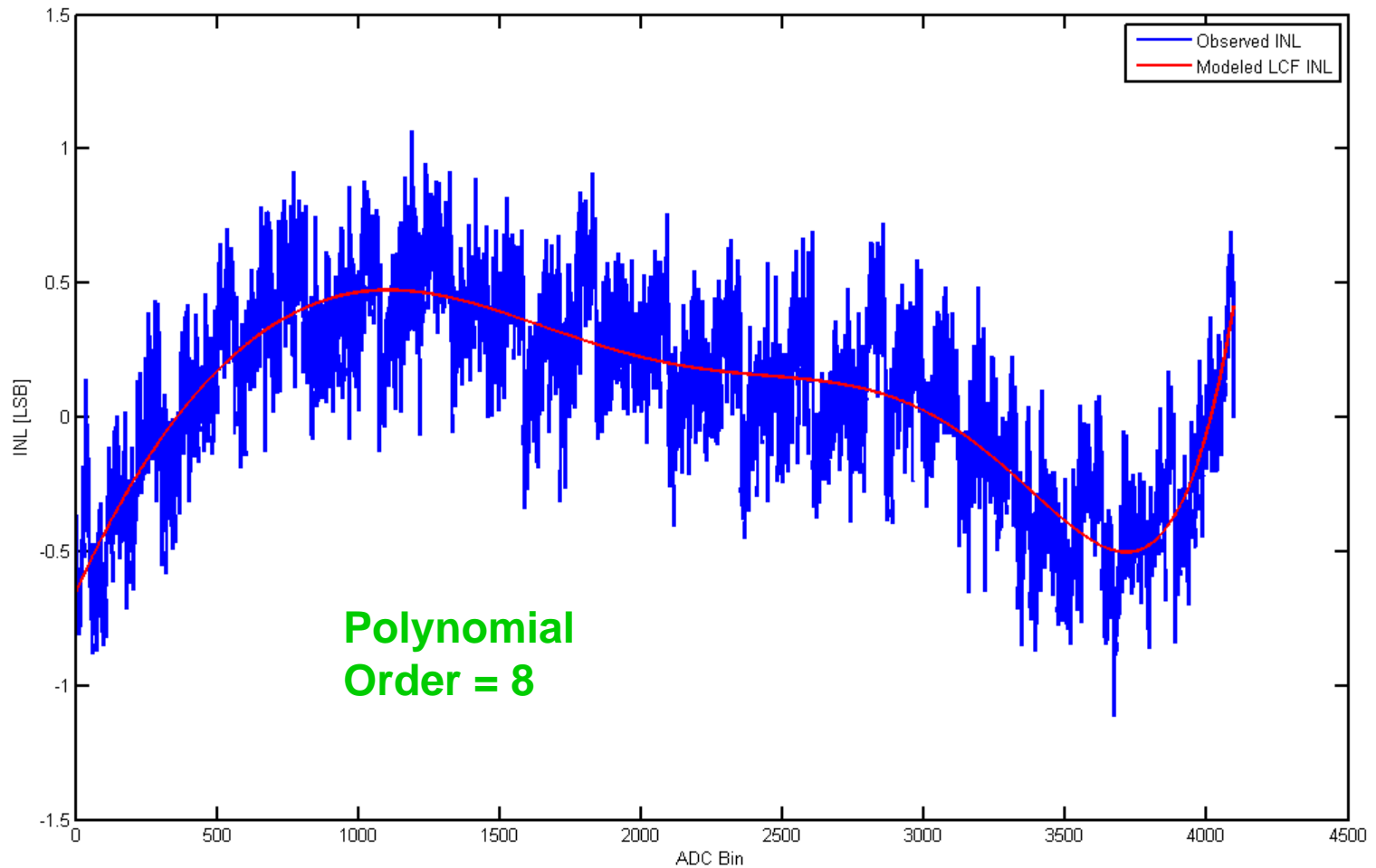

# HCF INL Model Illustration on Residue left by LCF

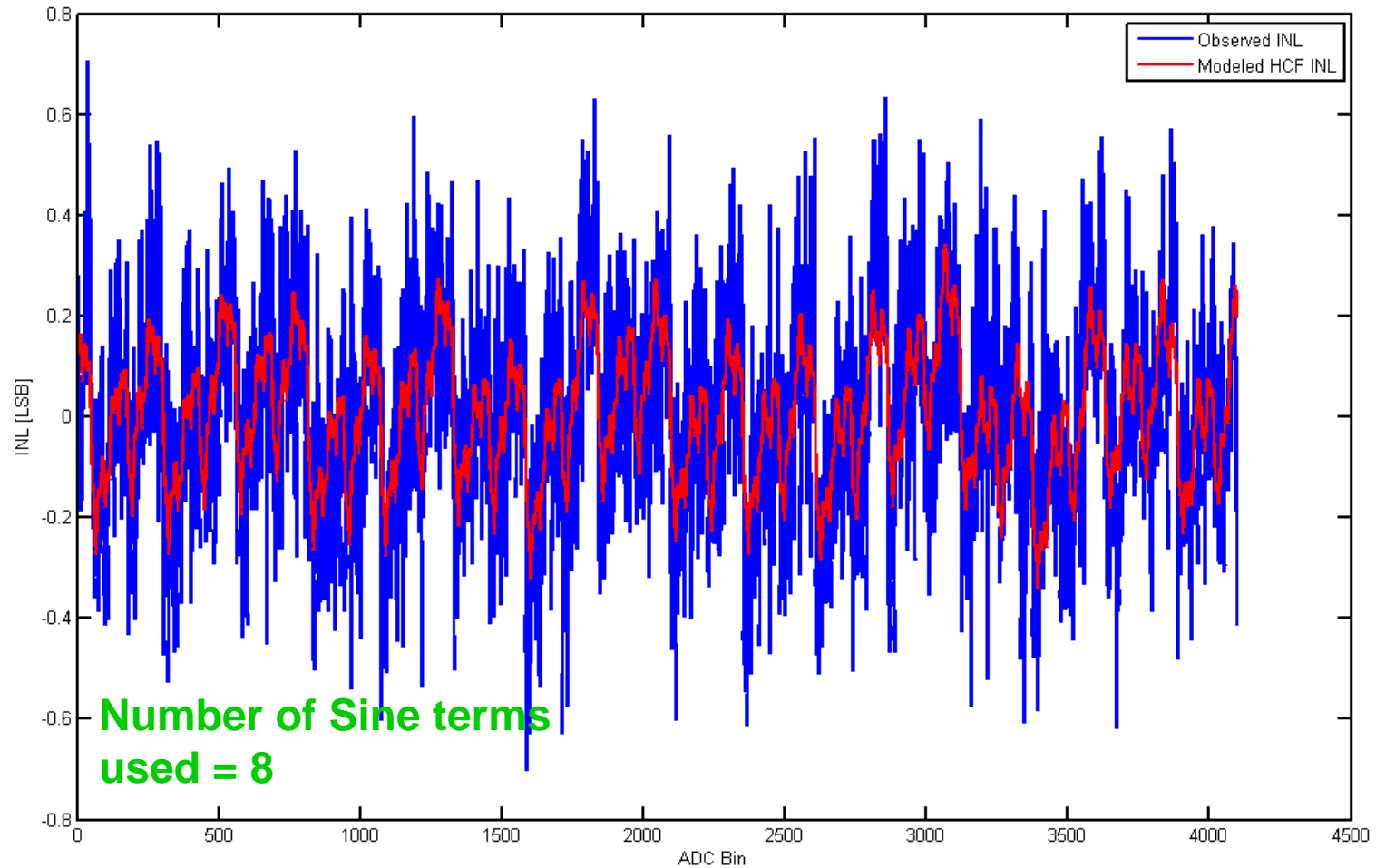

# HCF INL Model Illustration on Residue left by LCF

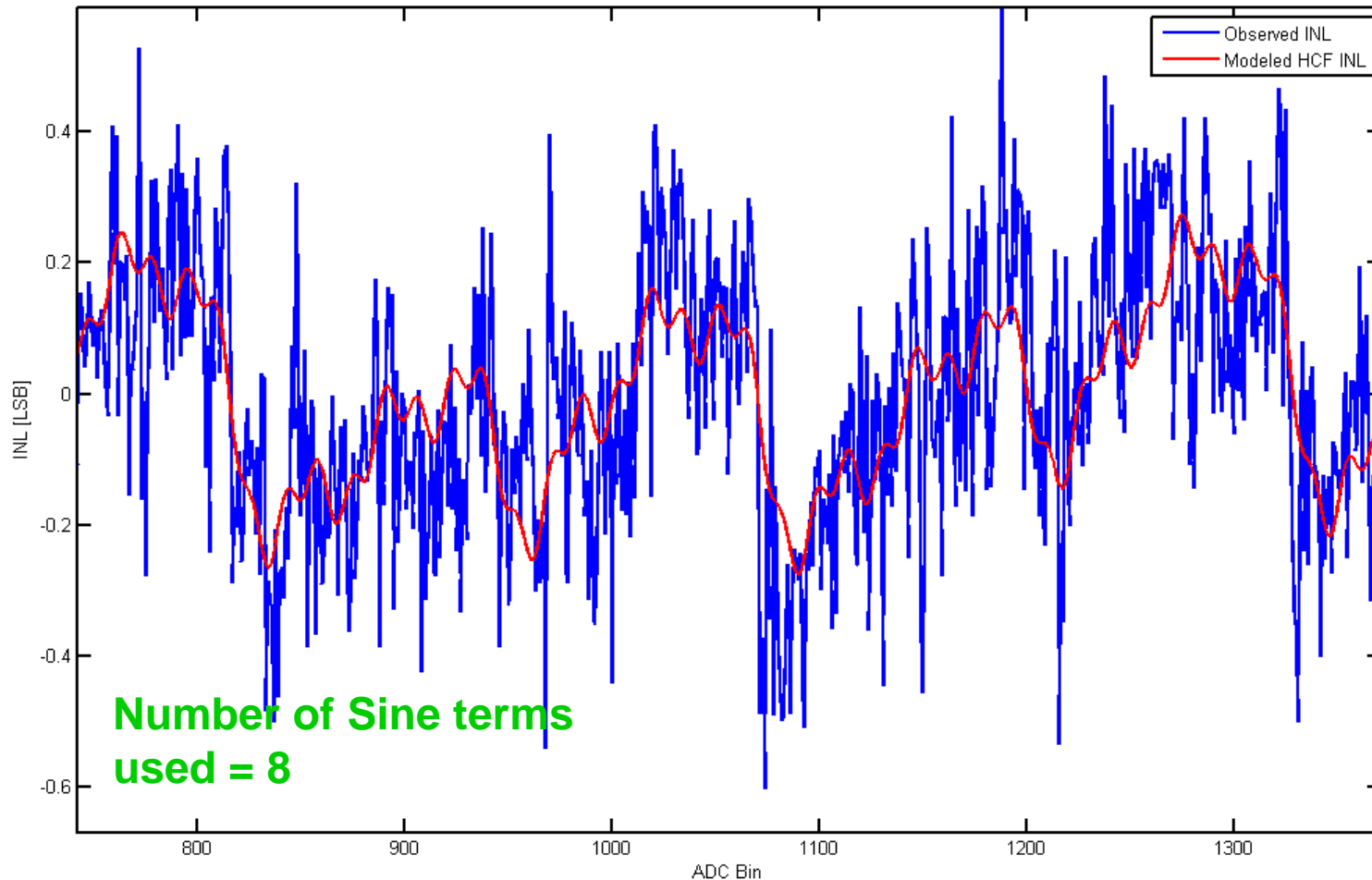

# Modeling Strategy

- Capture INL curves of an ADC over a Nyquist Zone, using a set of single tones
- Calculate LCF parameters (a set of polynomial coefficients) for each frequency
- Calculate the residue not modeled by LCF
- Average out the residue for all frequencies
- Use **'sum of sines'** to model the HCF

# Model Block Diagram

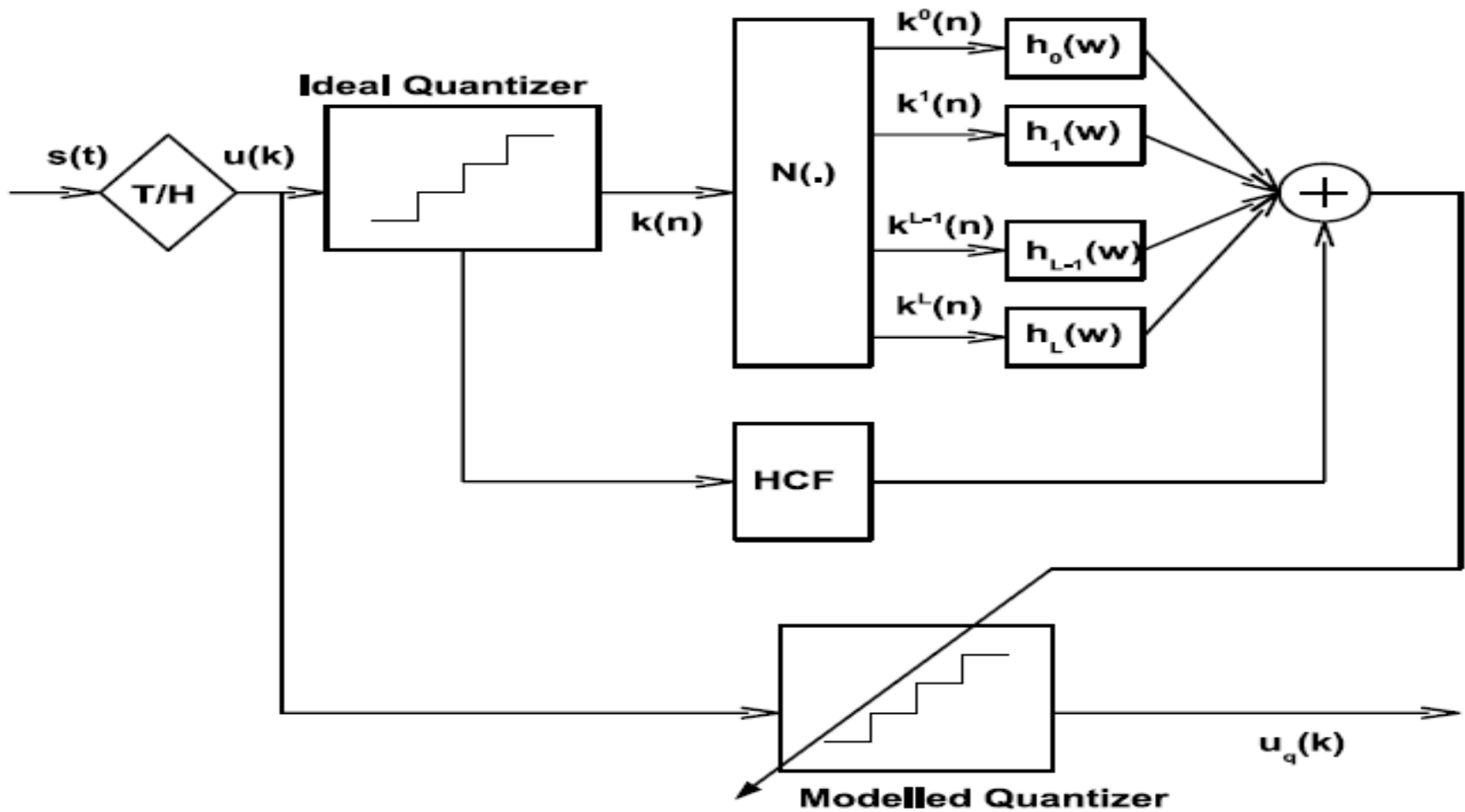

# Model Results for 2<sup>nd</sup> and 3<sup>rd</sup> Harmonics (LCF Only)

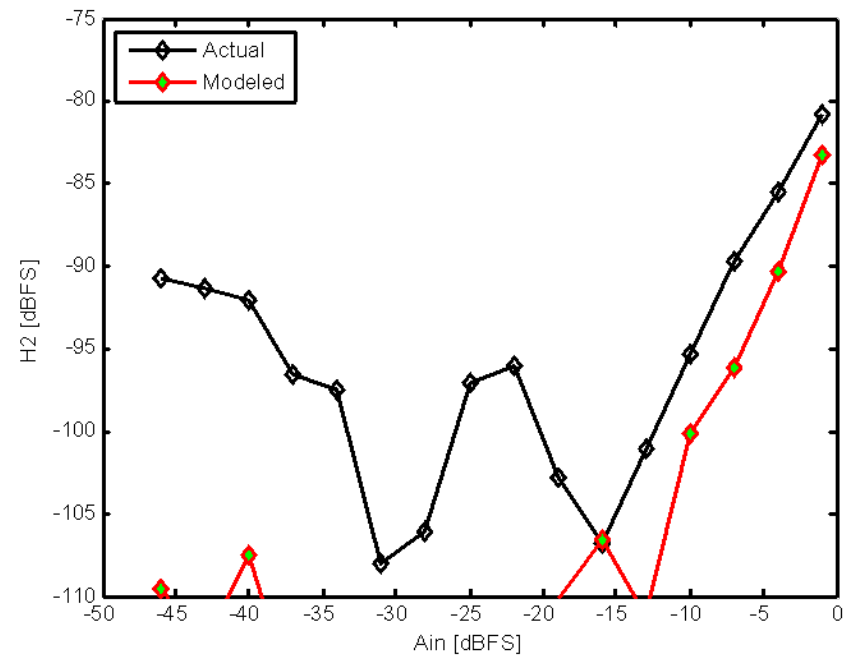
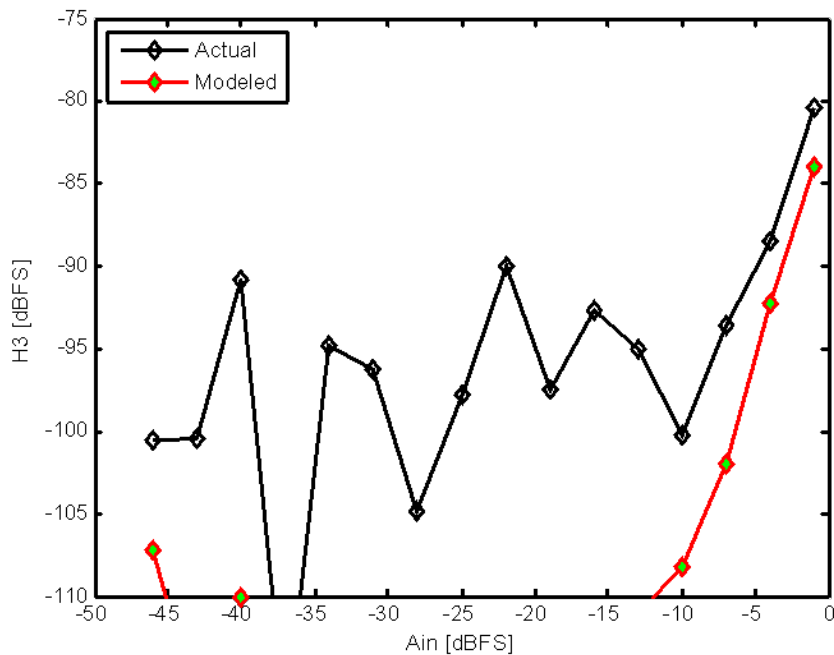

**$f_{in} = 60$  MHz**

**$f_s = 250$  MSPS**

# Model Results for 2<sup>nd</sup> and 3<sup>rd</sup> Harmonics (LCF+HCF)

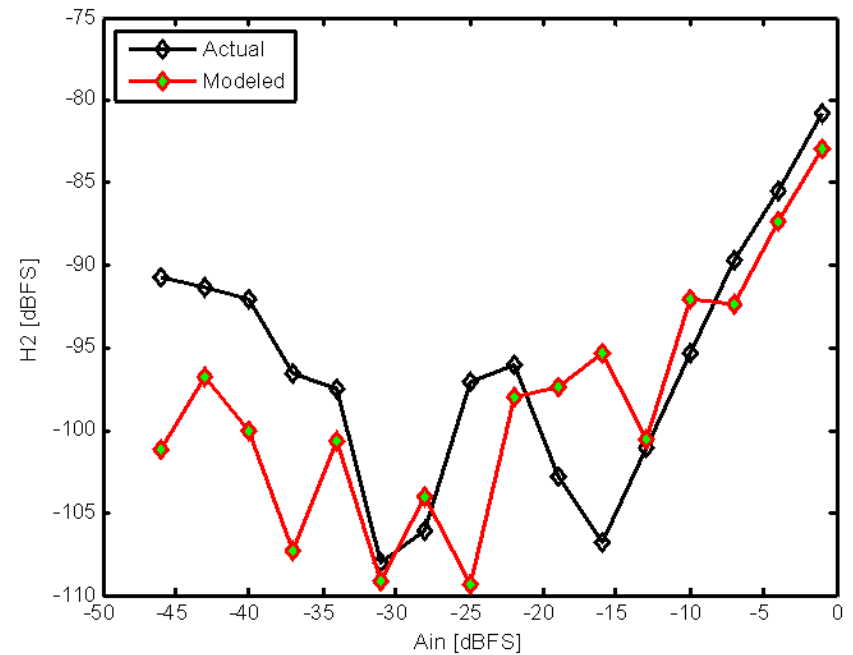
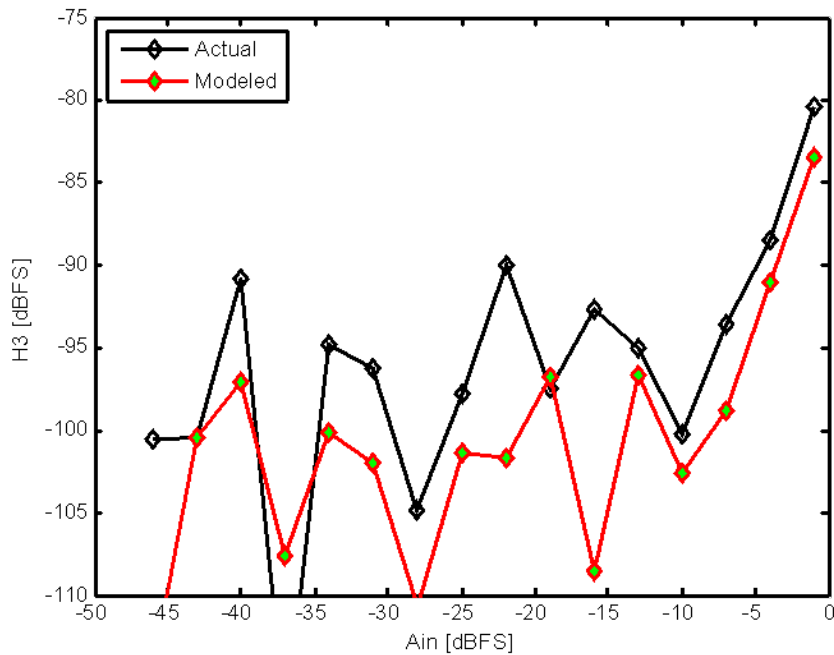

**fin = 60 MHz**

**fs = 250 MSPS**

# Modeling Results [THD]

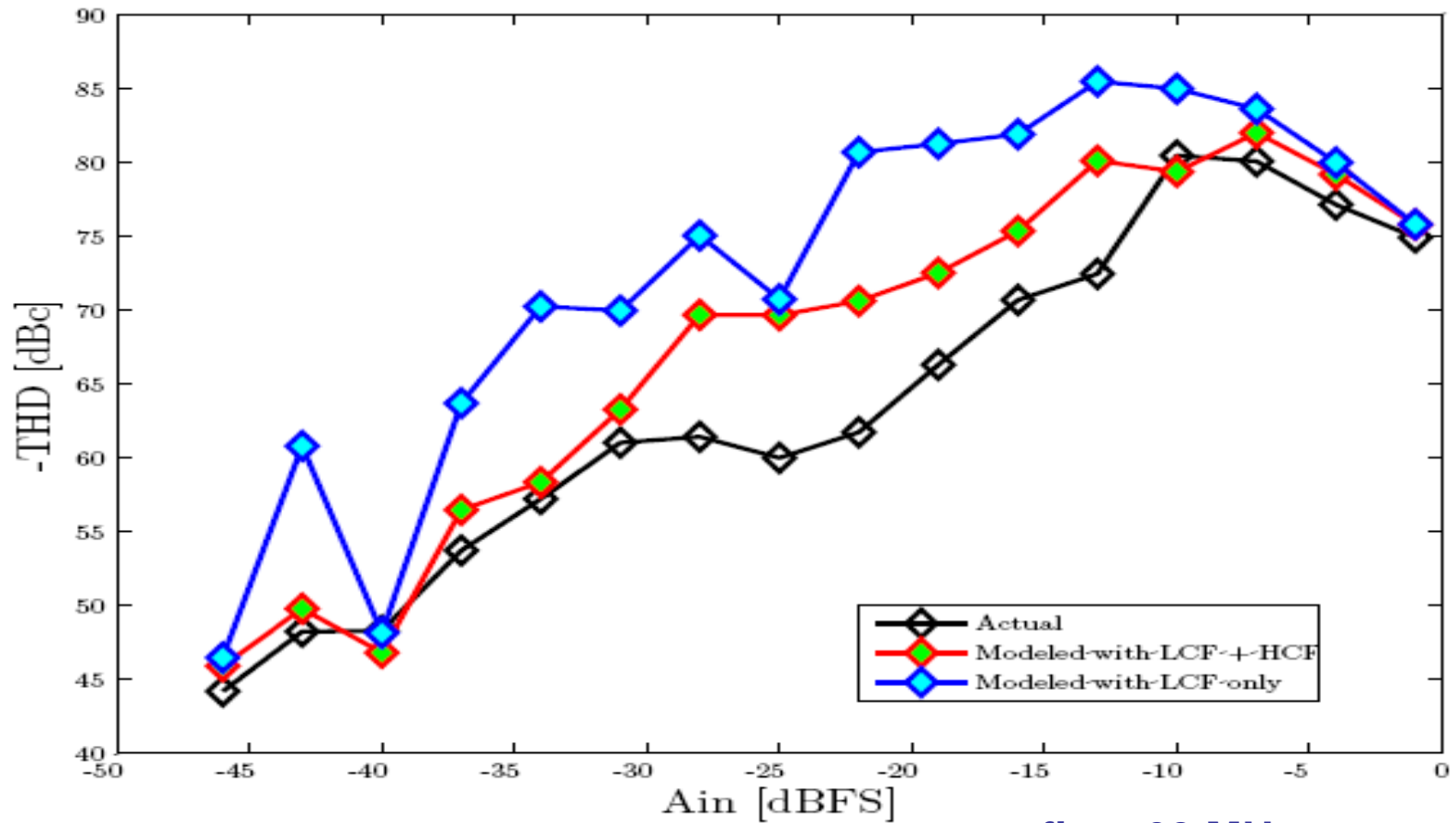

**fin = 60 MHz**

**fs = 250 MSPS**

# SFDR prediction

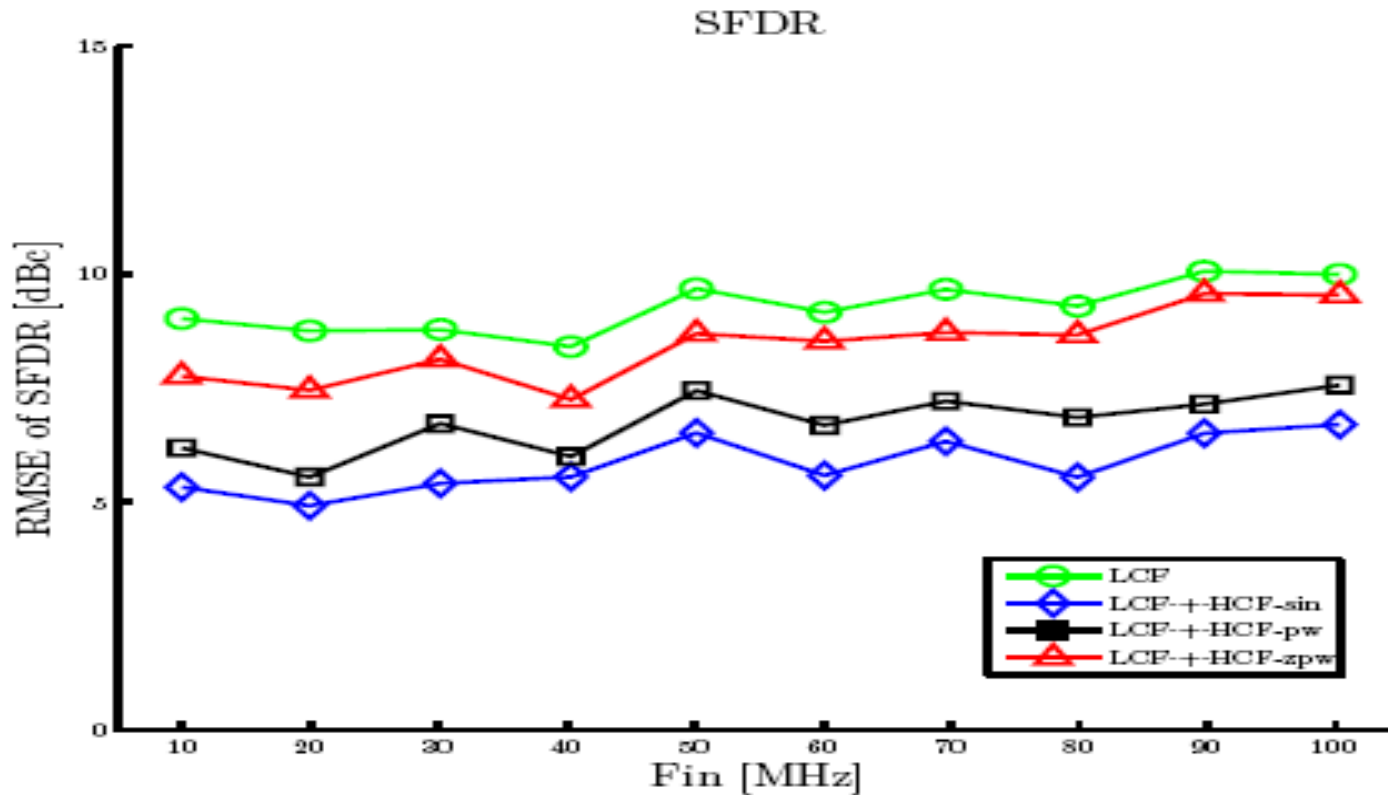

# THD prediction

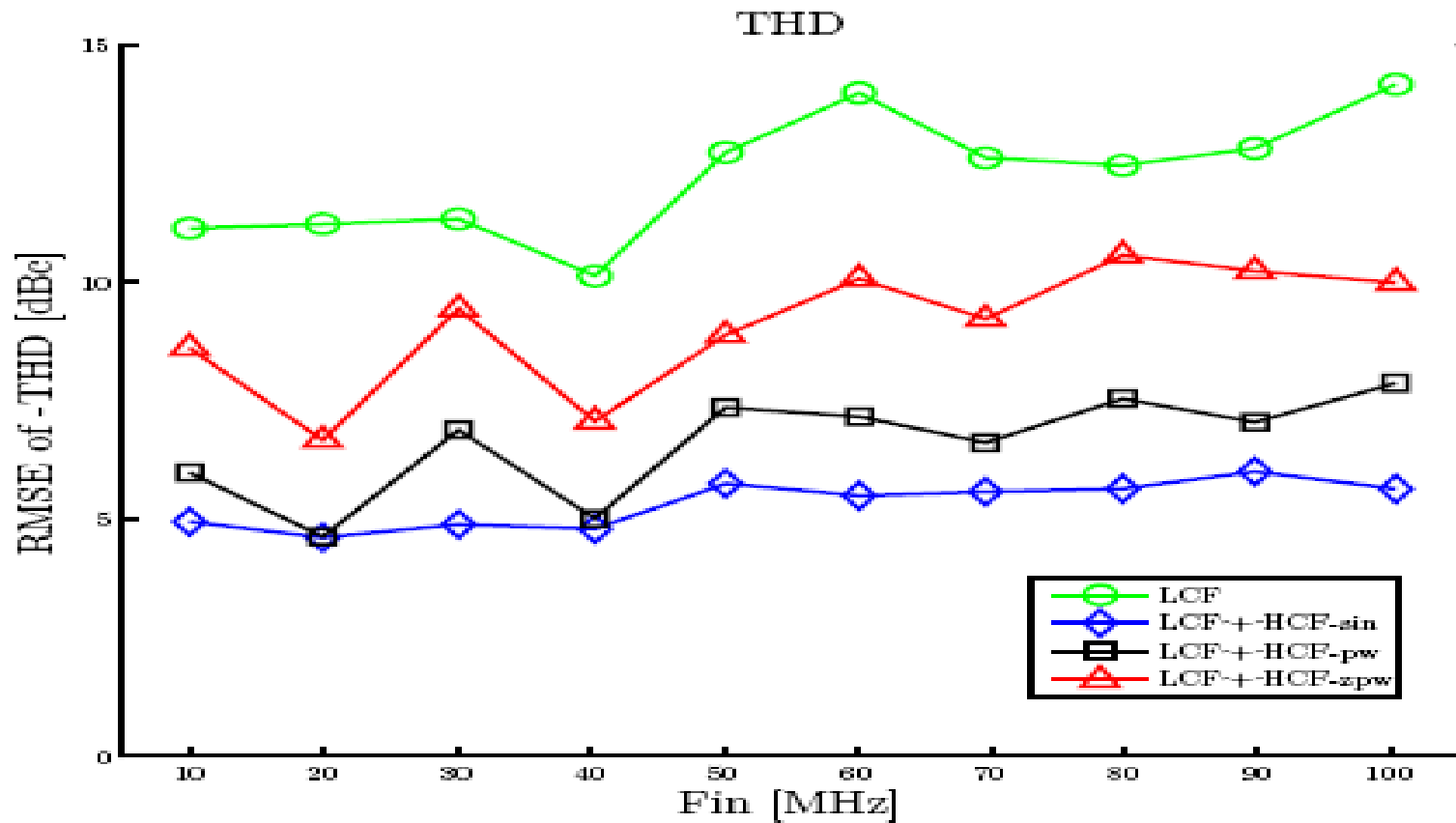

# Future Work

- Error in each bin of ADC has a memory
- INL calculation averages out error in each bin, which implies *lost information!*
- Need to define a model structure that remembers the '*path*' taken to each bin to predict the error correctly for that bin
- Use the model for correction

Thank you!

