

2010

System Verification of Flexray Communication Networks Through Behavioral Simulations



Candice Muller, Maurizio Valle

DIBE - Dipartimento di Ingegneria Biofisica ed Elettronica

Università degli Studi di Genova, Italy

Motivation

- Amount of **electronics** used in vehicles systems is **increasing**;
- The in-vehicle communication networks are becoming **highly distributed systems**;
- Network **complexity** is increasing;
- **Safety requirements** require higher **performance** and system **reliability**;
- Hardware **components** and network topology have significant **impact** on the system **signal integrity**;
- **Verification** is compulsory in **early stages** of design process;
- The use of **prototypes** to the design verification is **expensive, time consuming** and **inflexible**.



Proposed Solution

To use behavioral simulations for the verification of the in-vehicle communication network during the design phase.

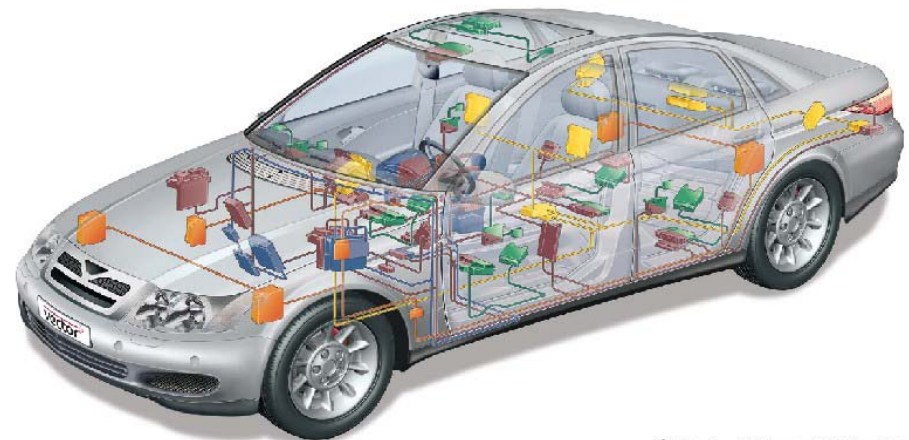

Advantages

- Behavioral simulations allow to:
 - Easily **test and verify** different network **topologies** and components;
 - **Forecast problems** in the early stages of the design process;
 - **Reduce** network **verification cycle**;
 - **Reduce** the number of hardware **prototypes**;
 - Reduce **cost** and **time to market**;
 - Run **statistical analysis** (Corner and Monte Carlo).

Aims of This Work

- To **verify** through behavioral simulations:
 - The most **critical parameters** of the **physical layer** (e.g. propagation delay, truncation, etc.) during network development;
 - The **feasibility of specific network topologies**, considering cable lengths, terminations, etc;
- To **compare** in terms of computational effort and accuracy two **bus line models**:
 - Lossless;
 - Lossy.

Flexray Network Design Challenges

- **To ensure sufficient signal integrity in the analog bus:**
 - The network topology, cable lengths, the presence of active and passive stars, and the node terminations can have significant impact on the signal integrity;
 - Parameter variations can cause undesired network behavior;
 - Errors on the electrical physical layer can impact the behavior of the entire communication system, compromising the system reliability.

Flexray Network Design Challenges...

Flexray Frame Format

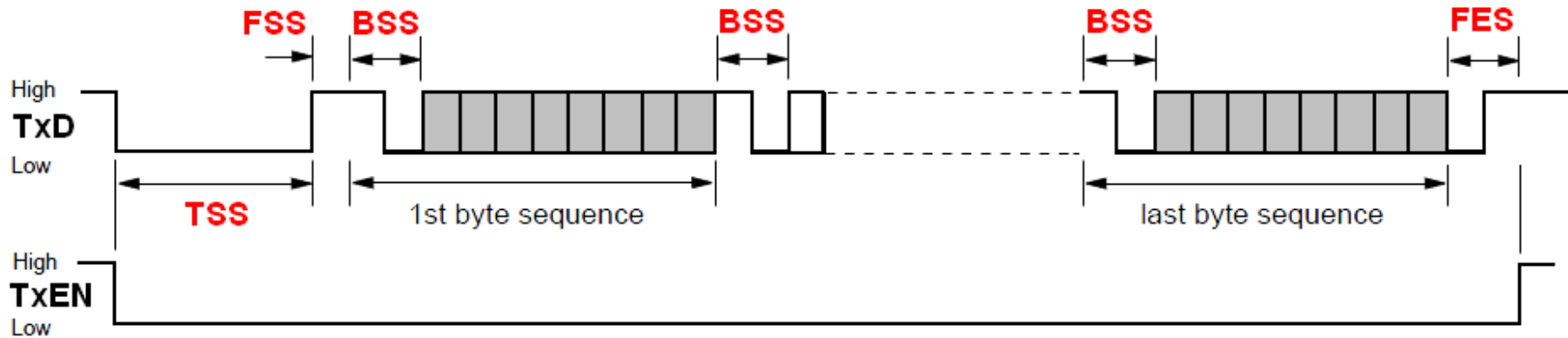

Flexray Network Design Challenges...

- Parameters need to be checked against specification:

– Propagation delay;

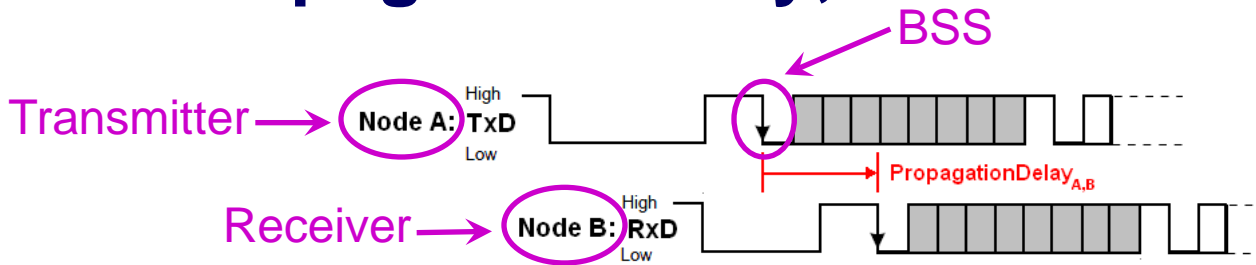

– Asymmetric delay;

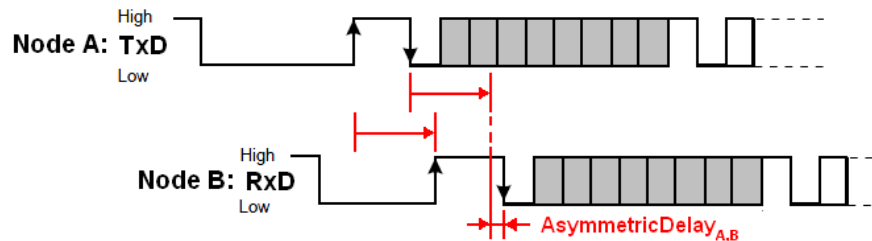

Flexray Network Design Challenges...

– TSS Truncation;

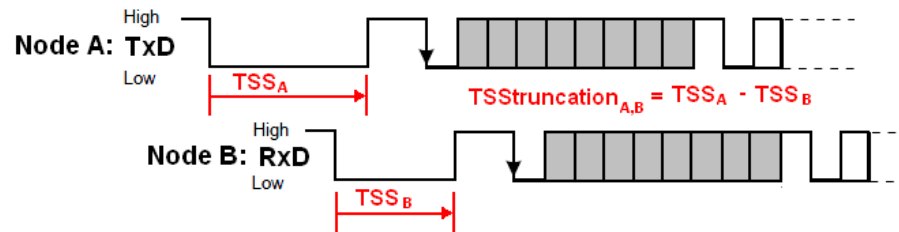

– Bit deformation;

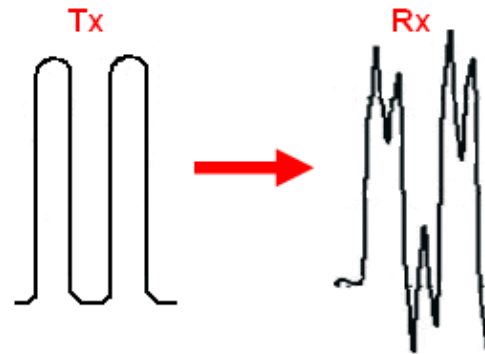



Modeling language: **VHDL-AMS**

- Industry standard;
- Widely supported by the available mixed-mode circuit simulators;
- Allows modeling analog, digital and mixed-mode circuits;
- Allows use of multiple energy domains (e.g. thermal-electrical).

Network Components...

A. Transceiver:

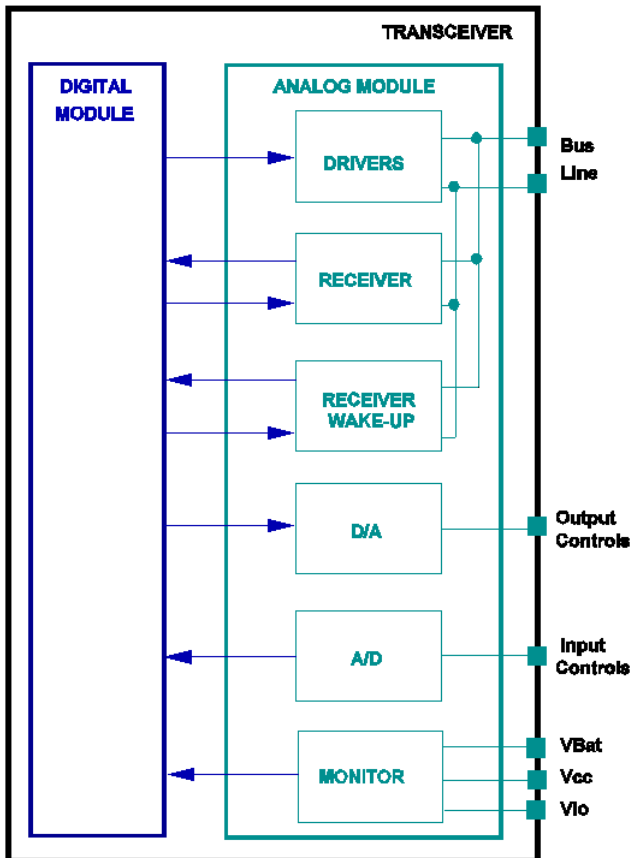

- Mixed-mode circuit;
- Hierarchically composed model;
- Interface between digital controller and analog bus;
- Different abstraction levels.

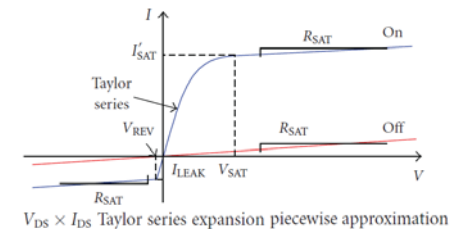
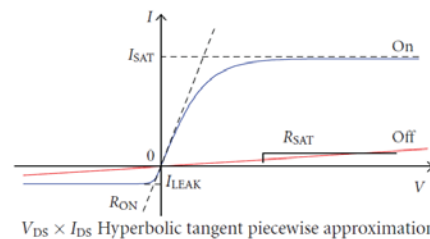
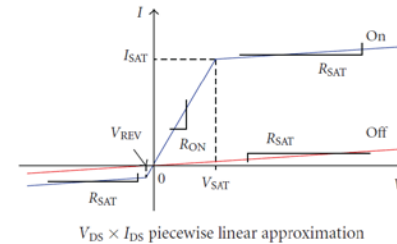

Network Components...

B. Termination:

- Match with bus impedance -> reduce reflections;
- Split termination -> better EMC.

C. Common Mode Chokes:

- May be used to improve emission and immunity performance;
- Transformer equations;
- M = mutual inductance.

$$v_1 = L_1 \frac{diL_1(t)}{dt} + M \frac{diL_2(t)}{dt} + i_1 R$$

$$v_2 = L_2 \frac{diL_2(t)}{dt} + M \frac{diL_1(t)}{dt} + i_2 R$$

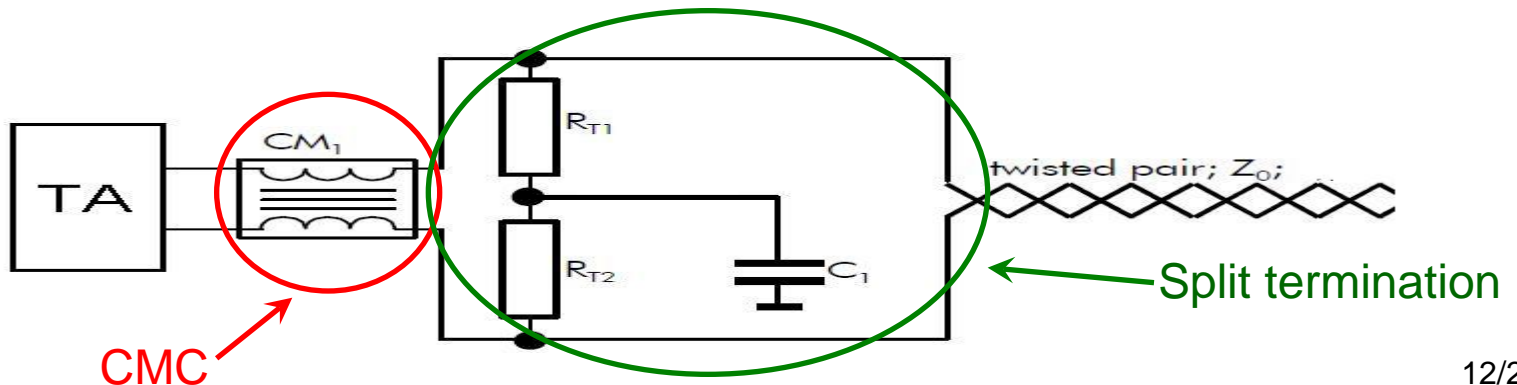

Network Components...

D. Transmission line:

- **Lossless** model:
 - Two-port network;
 - Characteristic impedance;
 - Time delay.
- **Lossy** model:
 - RLGC model;
 - Series of two-ports elementary components, each one representing a short segment of the transmission line.

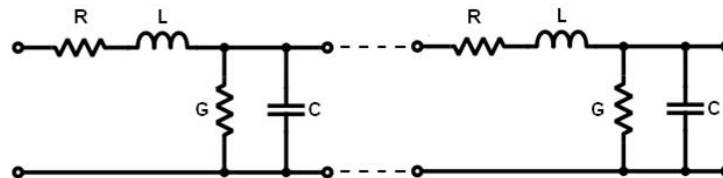

Transceiver Model Validation

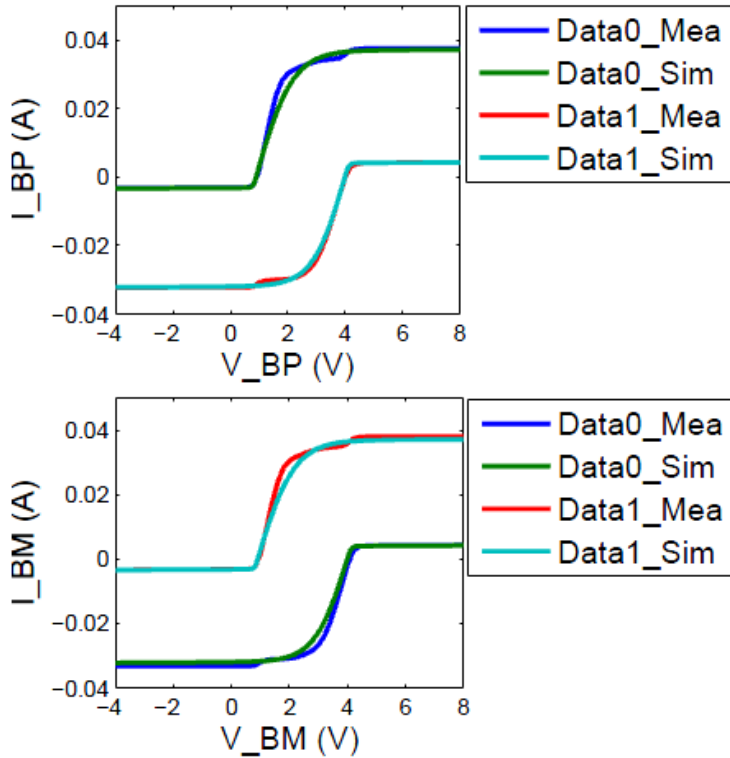

Drivers $i \times v$ characteristics

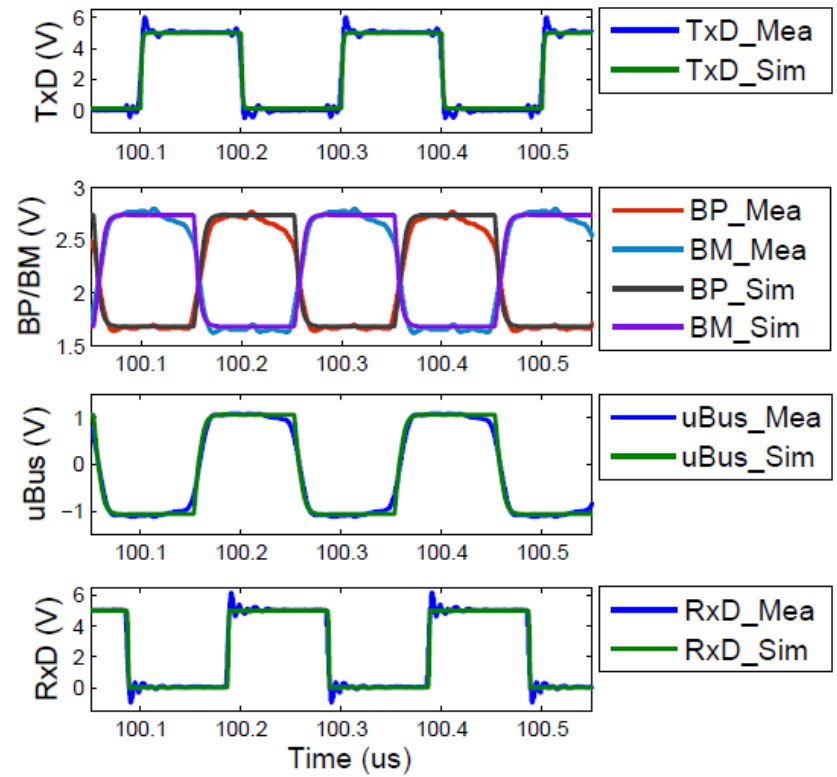

Bus signal integrity

Flexray System Verification

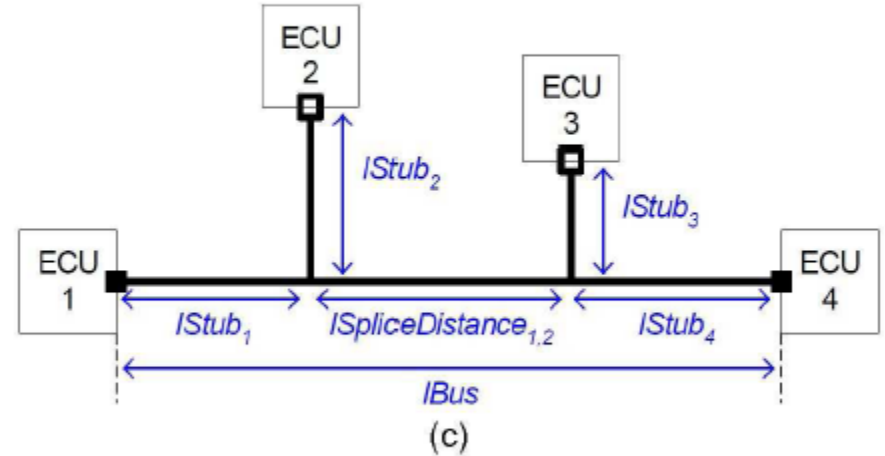
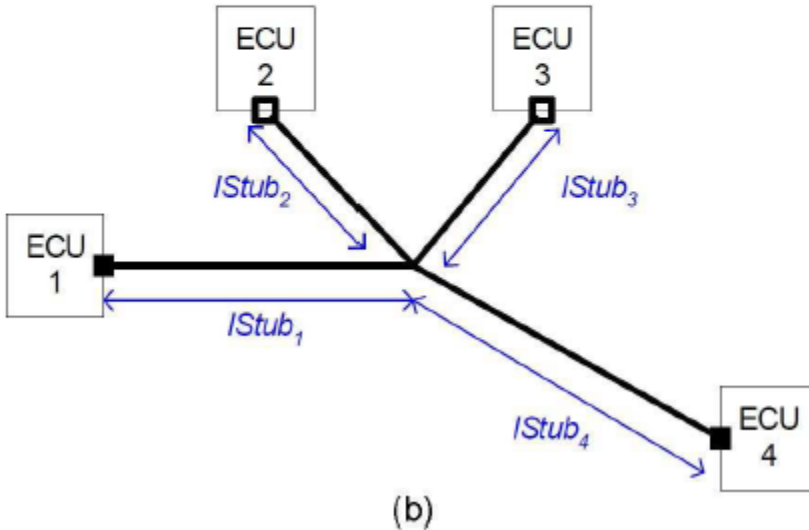
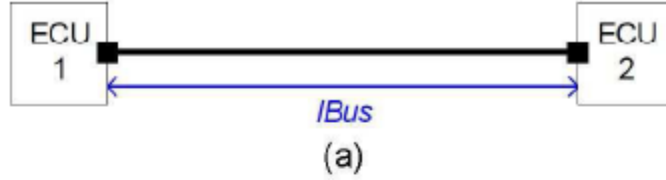

Network topologies:

(a) Point-to-point

(b) Passive Star

(c) Linear bus

(a) Point-to-point topology:

Low impedance split termination:

- $R_{TA}/R_{TB} = 47.0 \text{ Ohms}$
- $C1 = 4.7\text{nF}$

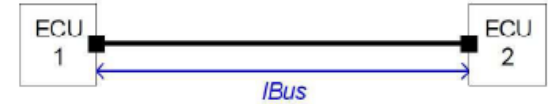
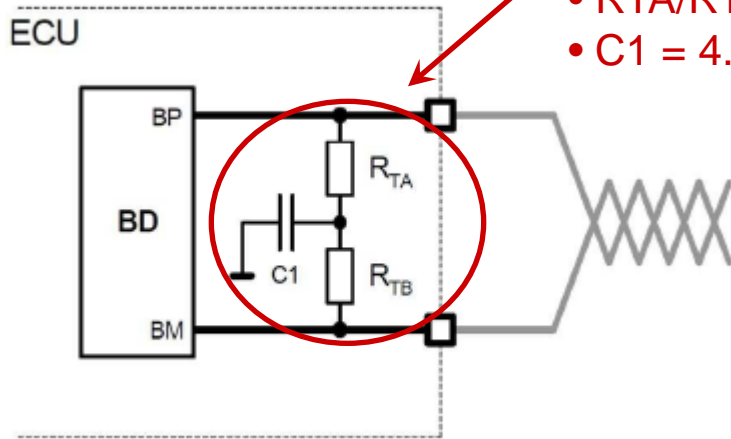

• $l_{Bus} = 9.0\text{m}$

Flexray specification:

- $cPropagationDelayMax = 2.5\mu\text{s}$
- $dFrameTSSTruncationMax = 1.35\mu\text{s}$
- $dAsymmetricDelay = 37.5 \text{ ns}$

Parameter	RLGC	Lossless
Propagation delay [ns]	89	82
TSS truncation [ns]	166	168
Asymmetric delay [ns]	1	-1

(b) Passive star topology:

- $I_{Stub1} = 2.5m$;
- $I_{Stub2} = 0.6m$;
- $I_{Stub3} = 1.7m$;
- $I_{Stub4} = 3.8m$.

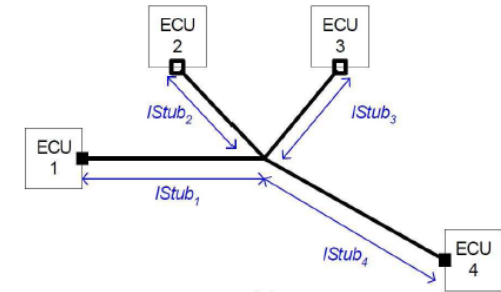

Transmitter = ECU 1

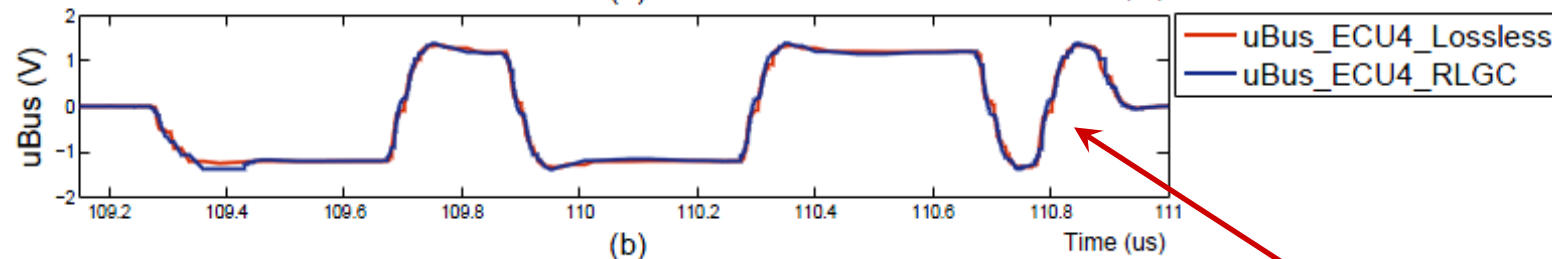
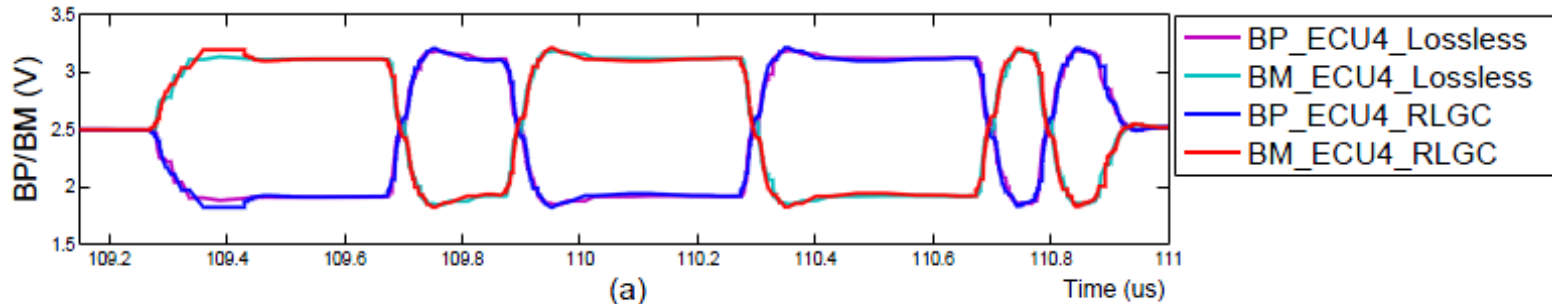

Correlation coefficient = 0.9945*

Correlation coefficient: Measure of the tendency of two variables to vary together; indicates the degree of relationship between two sets of scores, a number that can range from +1.0 (perfect positive correlation) to -1.0 (perfect negative correlation).

(b) Passive star topology...

PS PROPAGATION DELAY

Tx \ Rx	ECU 1	ECU 2	ECU 3	ECU 4
ECU 1	33n 33n	62n 63n	63n 63n	89n 89n
ECU 2	69n 69n	33n 33n	56n 56n	77n 75n
ECU 3	67n 67n	54n 55n	31n 31n	75n 74n
ECU 4	89n 89n	69n 70n	70n 61n	33n 33n

PS TSS TRUNCATION

Tx \ Rx	ECU 1	ECU 2	ECU 3	ECU 4
ECU 1	173n 173n	168n 169n	168n 169n	155n 157n
ECU 2	160n 162n	171n 171n	169n 168n	160n 162n
ECU 3	165n 165n	171n 171n	175n 175n	164n 165n
ECU 4	154n 157n	167n 167n	167n 167n	173n 173n

Flexray specification:

- $cPropagationDelayMax = 2.5\mu s$
- $dFrameTSSTruncationMax = 1.35\mu s$

Lossless
RLGC

(b) Passive star topology...

- Increasing ECU 1 and ECU 4 cable lengths:

- $IStub1 = 16.2m$;
- $IStub2 = 0.6m$;
- $IStub3 = 1.7m$;
- $IStub4 = 7.8m$.

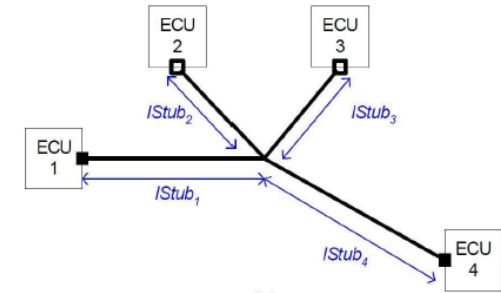

- Cable distance between ECUs 1 and 4: **24m**

- uBus Correlation coefficient between simulations with lossless and RLGC cables:

- ECU 1 = 0.9985;
- ECU 2 = 0.9962;
- ECU 3 = 0.9950;
- ECU 4 = 0.9986.

Maximum cable length
between two ECUs
recommended by Flexray
specification = 24m

(c) Bus topology:

- $I_{Stub1} = 4.0\text{m}$;
- $I_{Stub2} = 0.6\text{m}$;
- $I_{Stub3} = 0.8\text{m}$;
- $I_{Stub4} = 3.5\text{m}$;
- $I_{SpliceDistance1,2} = 1.0\text{m}$.

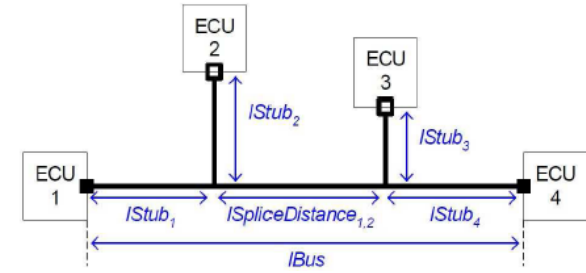

Transmitter = ECU 1

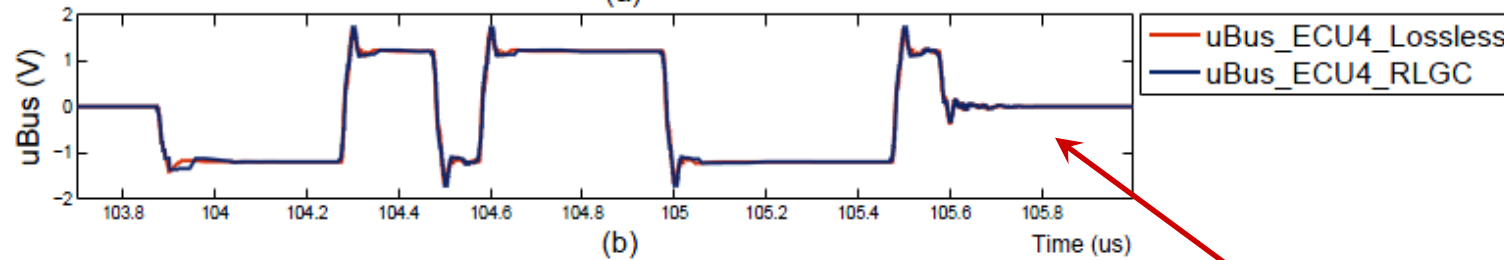
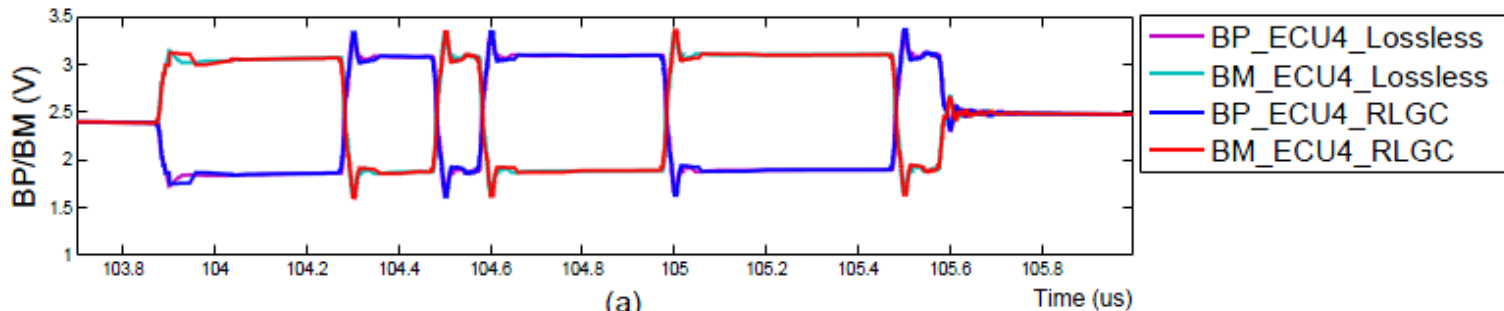

Correlation coefficient = 0.9952

(c) Bus topology:

BUS PROPAGATION DELAY

Tx \ Rx	ECU 1	ECU 2	ECU 3	ECU 4
ECU 1	33n 33n	58n 61n	68n 70n	88n 90n
ECU 2	62n 63n	33n 33n	49n 50n	70n 69n
ECU 3	71n 71n	48n 48n	31n 31n	59n 60n
ECU 4	90n 90n	66n 67n	59n 60n	33n 33n

BUS TSS TRUNCATION

Tx \ Rx	ECU 1	ECU 2	ECU 3	ECU 4
ECU 1	174n 173n	173n 171n	172n 170n	167n 167n
ECU 2	169n 168n	171n 170n	170n 169n	164n 165n
ECU 3	169n 169n	173n 172n	175n 175n	173n 171n
ECU 4	166n 166n	169n 169n	171n 170n	173n 173n

Flexray specification:

- $cPropagationDelayMax = 2.5\mu s$
- $dFrameTSSTruncationMax = 1.35\mu s$

Lossless
 RLGC

(c) Bus topology:

- Adding a **low impedance split termination** in **ECU 2** the bus DC load is:

$$R_{DCLoad} = \frac{1}{\frac{1}{97} + \frac{1}{97} + \frac{1}{2600} + \frac{1}{97}} = 31.94\Omega$$

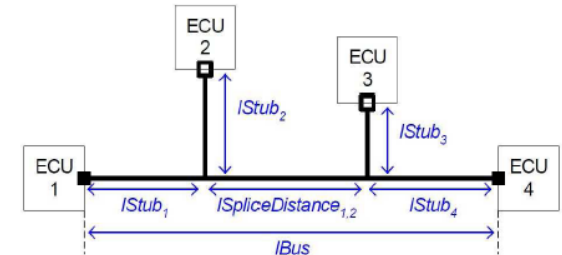

Flexray specification:

- Bus load Min = 40 Ohms
- Bus load Max = 55 Ohms

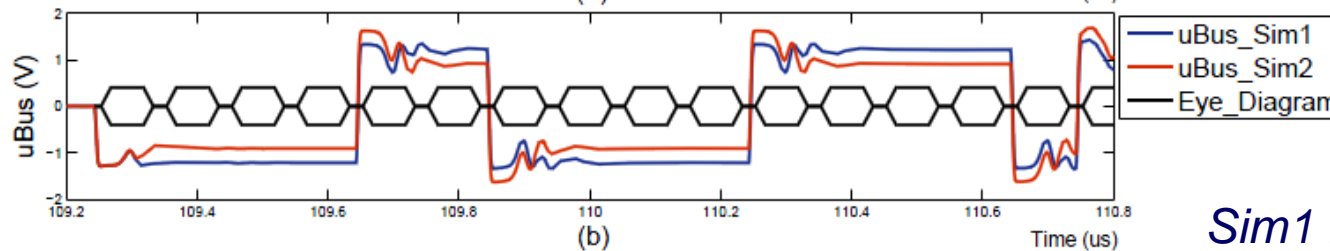
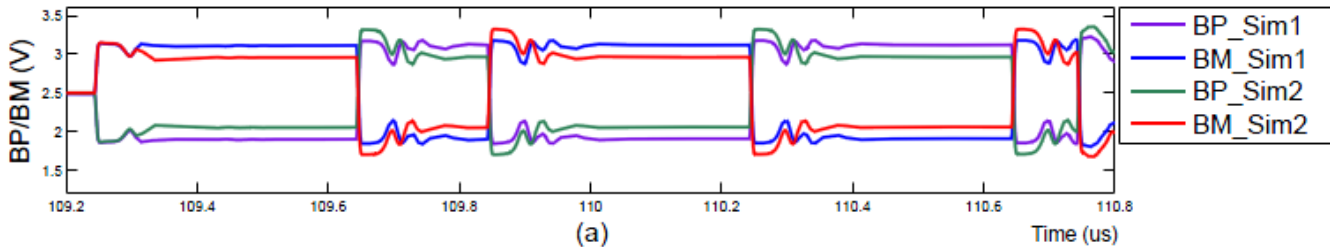

Sim1 load = 46.75Ohms
Sim2 load = 31.94Ohms

(c) Bus topology:

- Inverting termination of ECU 3 and ECU 4:

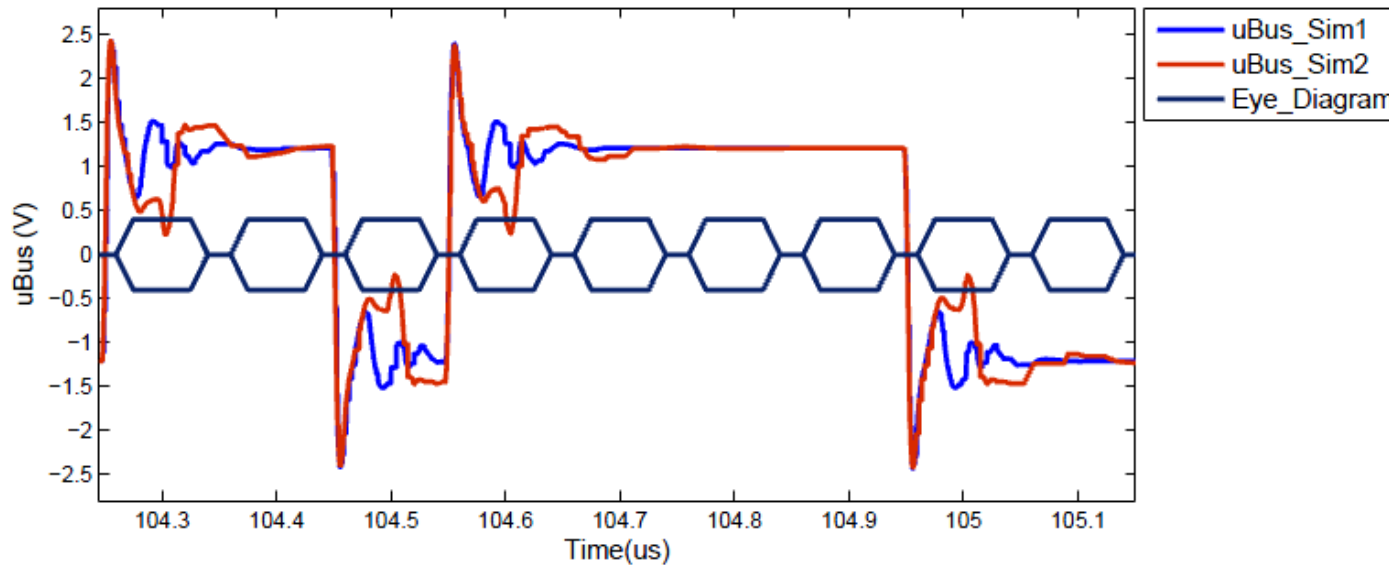
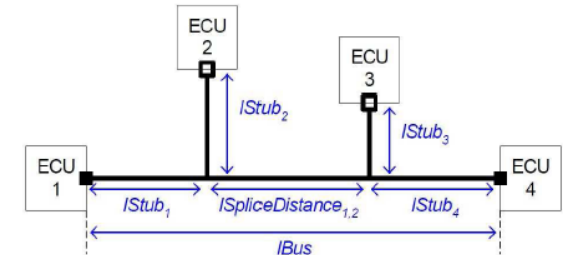

Flexray specification recommends the use of low impedance split termination in the two ECUs that have the maximum electrical distance on the bus and high ohmic split termination in the other ECUs.



Computational Effort Comparison:

CPU USAGE TIME [s]

Network Topology	RLGC Model	Lossless Model
Point-to-point	3246.6	21.8
Passive Star	3414.0	39.0
Linear Bus	4404.4	34.6

Conclusion

- The **transmission line** model has **big impact** in the **computational effort**;
- The **lossless** model bus line model has presented **accurate** results: no significant difference in the values of the analysed parameters using the lossless and RLGC cable models was detected;
- **Behavioral simulations** help on developing **robust** networks;
- **Behavioral simulations** help on accelerated **system-level verification**.



Thanks for your attention!

